

DONNE DU STYLE  
À VOTRE CUISINE



**focus** line

---

---

Il y a des moments dans la vie qui restent de bons souvenirs, tel que partager un délicieux repas avec les gens que vous aimez.

Nous voulons y participer à vous rendre apte de créer des délicieux repas, même s'il s'agit d'une fête familiale.

Vous aimez la vie, vous aimez la création, nous sommes FOCUS et vous êtes notre focus, nous sommes ce que nous voulons être.

*There are moments in life that remain good memories forever, such as sharing a delicious meal with the people you love.*

*We want to participate to make you able to create delicious meals, even if it is a family celebration.*

*You love life, you love creation we are FOCUS and you are our focus, we are what we want to be.*

---

---

# SOMMAIRE

## INDEX

011 **FOURS**  
*OVENS*

---

---

034 **MICRO-ONDES**  
*MICRO-WAVES*

---

---

046 **PLAQUES DE CUISSON**  
*HOBBS*

---

---

092 **HÔTTES ASPIRANTES**  
*HOODS*

---

---

132 **REFRIGÉRATEURS**  
*COOLING*

---

---

142 **LAVAGE**  
*WASHING*

---

---

154 **ÉVIERS ET MÉTIGEURS**  
*SINKS AND MIXERS*

---

---







## FOURS OVENS

Conçu en collaboration avec de grand chefs, les fours FOCUS sont élaborés avec le plus grand soin, ils sont aussi équipés avec les dernières technologie avant-gardistes pour vous permettre d'exprimer vos exigences et performances.

*Designed in collaboration with great chefs, FOCUS ovens are made with great care, they are also equipped with the latest technology, cutting edge allow you to express your requirements and performance.*







## LES FONCTIONS DES FOURS OVENS FUNCTIONS

Le four idéal doit être doté d'une diffusion uniforme de la chaleur et du contrôle précise de la température pour garantir un cuisson homogène avec une faible consommation d'énergie.

la sécurité de vos enfant est assuré par la porte froide donc la chaleur est maintenue du four toute en conservant une température extérieure de la porte très basse.

*The ideal oven must have a uniform heat distribution and precise temperature control to ensure even cooking with low energy consumption.*

*the safety of your child is insured by the cold door so the heat is maintained throughout the oven retaining an outside door temperature is low.*



# MODES DE CUISSON

## COOKING METHODS

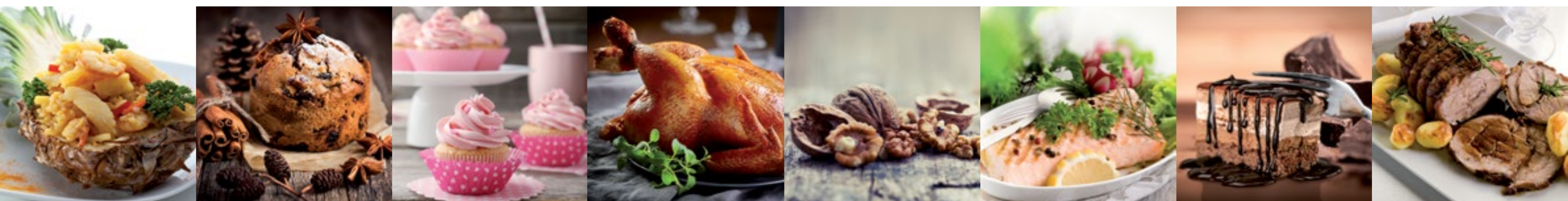

0

**La position 0**  
le four est fermé.  
*Position 0*  
the oven is closed.



**La lumière**  
Quand le four est fermé, la lampe s'allume pour permettre un contrôle visuel léger.  
*La lumière*  
When the oven is closed, the lamp lights to allow a slight visual control.



**La cuisson conventionnelle**  
La cuisson conventionnelle est la plus traditionnelle qu'on utilise surtout pour préparer les gâteaux et les pâtisseries.  
Les deux résistances, en même temps, diffusent la chaleur dans le four.  
**Conventional cooking**  
Conventional baking is the most traditional one mostly used to prepare cakes and pastries.  
The two resistors, at the same time, diffuse the heat in the oven.



**Résistance basse**  
On utilise la résistance basse pour chauffer directement la nourriture. Cette méthode est convenable pour cuire lentement ou pour chauffer des repas.  
**Low resistance**  
low resistance is used to directly heat the food. This method is suitable for slow cooking or heating food.



**Le demi grill**  
Cette méthode est convenable pour griller petites portions de viande.  
**The half grill**  
This method is suitable for grilling small portions of meat.



**Le plein grill**  
cette méthode est convenable pour griller de moyenne et de grande portions de steak, poisson, etc.  
**The full grill**  
This method is suitable for grilling medium and large portions of steak, fish, etc.



**Le ventilateur & grill plein**  
Cette méthode est convenable pour faire dorer rapidement et sceller dans les jus, tel qu'avec les biftecks, hamburgers, quelque légume, etc ... parce que le ventilateur aide.  
**Fan & full grill**  
This method is suitable for quick browning and sealing in juices, such as with steaks, hamburgers, some vegetables, etc ... because the fan help.



**Le ventilateur avec résistances haut & bas**  
Cette méthode de cuisson utilise les résistance inférieure et haut pendant que le ventilateur circule la chaleur.  
**The fan with up & down resistors**  
This cooking method uses lower and high resistance while the fan circulate the heat.



**Chaleur tournante**  
le ventilateur entouré par une résistance circulaire répartit la chaleur autour du four.  
C'est multifonction qui est la méthode la plus efficace de cuisson avec la multifonctions, les différents types de nourritures peuvent être cuits en même temps sans transfert de sent.  
**Convection**  
the fan surrounded by a circular resistance heat distribution around the furnace.  
It is multifunctional which is the most effective method of cooking with the multifunction, the different types of foods can be cooked in same time without transfer of smells.



**Le ventilateur avec résistance basse & circulaire**  
Cette méthode de cuisson s'appelle la multifonctions, elle permet de cuire 2 ou 3 repas en même temps sans que l'odeur se mixte.  
**The circular fan with low resistance**  
This cooking method is called multifunctional, it allows to cook 2 or 3 meals at the same time without the smell is mixed.



**Décongélation**  
Seul le ventilateur se met en fonction, sans production de la chaleur pour réduire le temps de décongélation de nourritures gelés.  
**Thawing**  
Only the fan will function without producing heat to reduce the defrosting time of frozen foods.



**Auto**  
L'accès aux recettes prédéfinies.  
**Auto**  
Access to preset recipes.



**Boost**  
Préchauffage Rapide.  
**Boost**  
Rapid preheating.



**Clean**  
Nettoyage rapide pour les fours avec des panneaux autonettoyants catalytiques.  
**Clean**  
Rapid cleaning for ovens with self-cleaning catalytic panels.



**Résistance inférieure avec ventilateur**  
Lower heating element with fan



**Tournebroche**  
On utilise cette fonction pour faire la rôtissoire.  
**Roasting jack**  
This function is used to make the roasting pan.

# FOURS ÉLECTRIQUES

## ELECTRIC OVENS

### QUADRA 66



- Four Multifonction
- 14 fonctions avec «PIZZA» & «PAIN»
- Inox 60 CM
- Commandes touches tactiles
- 58 Litres
- Recettes préinstallées
- Chaleur tournante
- Timer electronic
- Autonettoyant Catalyse
- Porte froide
- Fonction BOOST pour rejoindre rapidement la température choisie
- Classe Energétique A

- Multifunction Oven
- 14 Cooking functions including "PIZZA" & "BREAD"
- Stainless Steel 60 CM
- Touch Control panel
- 58 litres capacity
- Automatic cooking functions
- Convection
- Electronic timer and clock
- Catalytic cleaning cycle
- Tangential cooling ventilation
- BOOST function for quickly reaching the selected temperature
- Energy-efficiency class A



### FILO 66



- Four Multifonction
- 14 fonctions avec «PIZZA» & «PAIN»
- Inox 60 CM
- Commandes touches tactiles
- 58 Litres
- Recettes préinstallées
- Chaleur tournante
- Timer electronic
- Autonettoyant Catalyse
- Porte froide
- Fonction BOOST pour rejoindre rapidement la température choisie
- Classe Energétique A

- Multifunction Oven
- 14 Cooking functions including "PIZZA" & "BREAD"
- Stainless Steel 60 CM
- Touch Control panel
- 58 litres capacity
- Automatic cooking functions
- Convection
- Electronic timer and clock
- Catalytic cleaning cycle
- Tangential cooling ventilation
- BOOST function for quickly reaching the selected temperature
- Energy-efficiency class A



### SOFT 66



- Four Multifonction
- 14 fonctions avec «PIZZA» & «PAIN»
- Noir 60 CM
- Commandes touches tactiles
- 58 Litres
- Recettes préinstallées
- Chaleur tournante
- Timer electronic
- Autonettoyant Catalyse
- Porte froide
- Fonction BOOST pour rejoindre rapidement la température choisie
- Classe Energétique A

- Multifunction Oven
- 14 Cooking functions including "PIZZA" & "BREAD"
- Black Glass 60 CM
- Touch Control panel
- 58 litres capacity
- Automatic cooking functions
- Convection
- Electronic timer and clock
- Catalytic cleaning cycle
- Tangential cooling ventilation
- BOOST function for quickly reaching the selected temperature
- Energy-efficiency class A



### Logement d'encastrement

#### Installation drawing

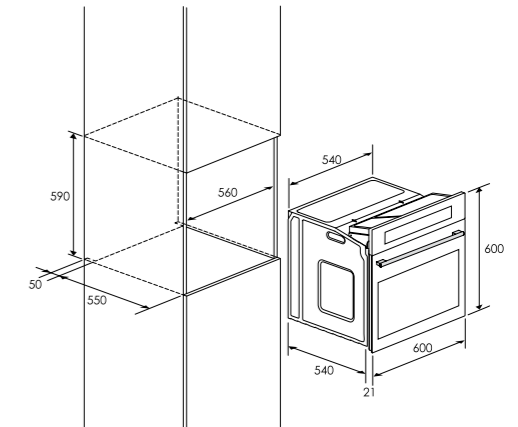

# FOURS ÉLECTRIQUES

## ELECTRIC OVENS

### QUADRA 56



- Four Multifonction
- 9 programmes
- Inox 60 CM
- Boutons
- 58 Litres
- Chaleur tournante
- Minuterie électronique
- Autonettoyant Catalyse
- Porte froide
- Classe Energétique A

- Multifunction Oven
- 9 Cooking functions
- Stainless Steel 60 CM
- Knobs
- 58 litres capacity
- Convection
- Electronic timer and clock
- Catalytic cleaning cycle
- Tangential cooling ventilation
- Energy-efficiency class A



### FILO 56

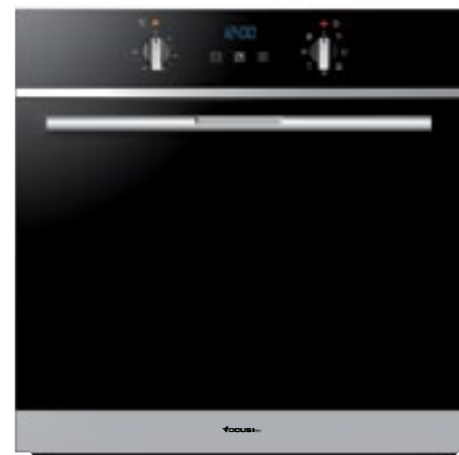

- Four Multifonction
- 9 programmes
- Inox 60 CM
- Boutons
- 58 Litres
- Chaleur tournante
- Minuterie électronique
- Autonettoyant Catalyse
- Porte froide
- Classe Energétique A

- Multifunction Oven
- 9 Cooking functions
- Stainless Steel 60 CM
- Knobs
- 58 litres capacity
- Convection
- Electronic timer and clock
- Catalytic cleaning cycle
- Tangential cooling ventilation
- Energy-efficiency class A



### SOFT 56



- Four Multifonction
- 9 programmes
- Noir 60 CM
- Boutons
- 58 Litres
- Chaleur tournante
- Minuterie électronique
- Autonettoyant Catalyse
- Porte froide
- Classe Energétique A

- Multifunction Oven
- 9 Cooking functions
- Black glass 60 CM
- Knobs
- 58 litres capacity
- Convection
- Electronic timer and clock
- Catalytic cleaning cycle
- Tangential cooling ventilation
- Energy-efficiency class A



### Logement d'encastrement

#### Installation drawing

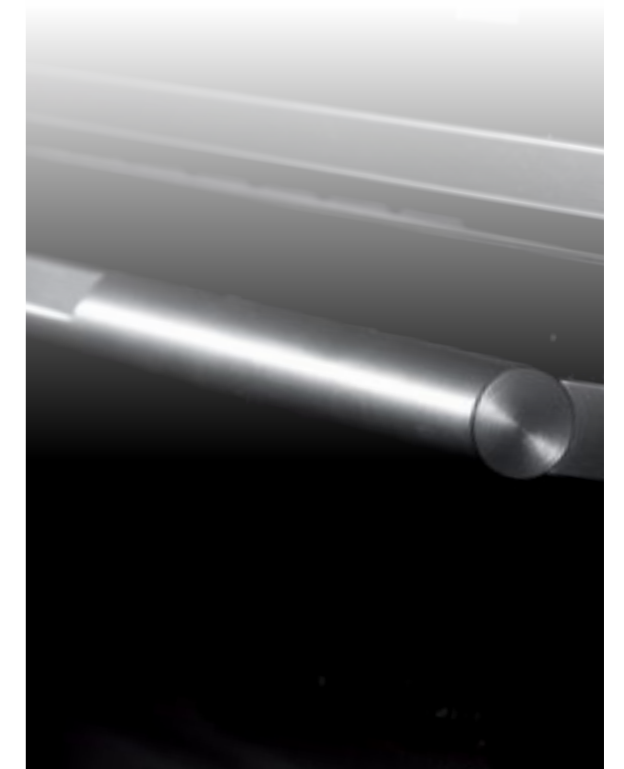
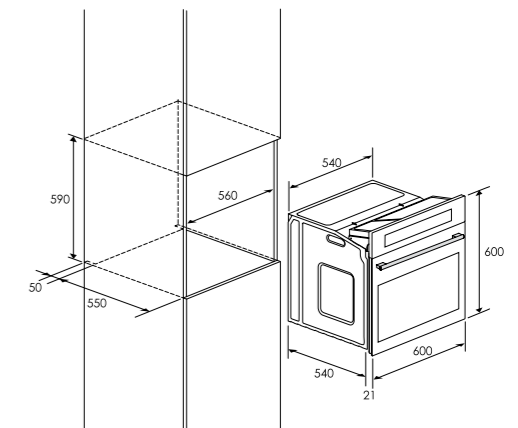

# FOURS ÉLECTRIQUES

## ELECTRIC OVENS

F 723X



- Four Multifonction
- 11 programmes
- Inox 60 CM
- Electronique
- 58 Litres
- Chaleur tournante
- Autonettoyant
- Minuterie électronique
- Porte froide
- Classe Energétique A

- Multifunction Oven
- 11 Cooking functions
- Stainless Steel 60 CM
- Electronic
- 58 litres capacity
- Convection
- Electronic timer and clock
- Catalytic cleaning cycle
- Tangential cooling ventilation
- Energy-efficiency class A



F 726X



- Four Multifonction
- 9 programmes
- Inox 60 CM
- Boutons «PULL»
- 58 Litres
- Chaleur tournante
- Minuterie électronique
- Autonettoyant Catalyse
- Porte froide
- Classe Energétique A

- Multifunction Oven
- 9 Cooking functions
- Stainless Steel 60 CM
- Pull Knobs
- 58 litres capacity
- Convection
- Electronic timer and clock
- Catalytic cleaning cycle
- Tangential cooling ventilation
- Energy-efficiency class A



F 721X



- Four Ventilé
- 7 programmes
- Inox 60 CM
- Boutons
- 58 Litres
- Chaleur tournante
- Minuterie électronique
- Porte froide
- Classe Energétique A

- Convection Oven
- 7 Cooking functions
- Stainless Steel 60 CM
- Knobs
- 58 litres capacity
- Convection
- Electronic timer and clock
- Tangential cooling ventilation
- Energy-efficiency class A



Logement d'encastrement  
Installation drawing

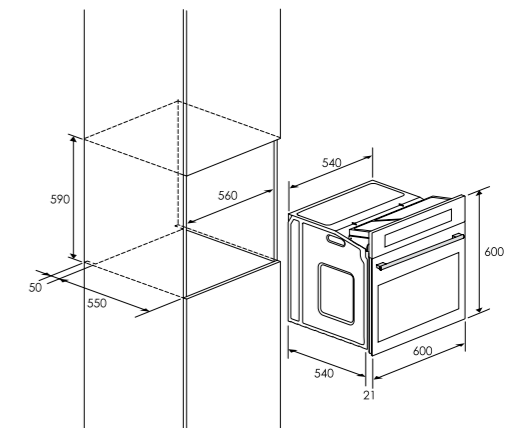

# FOURS ÉLECTRIQUES

## ELECTRIC OVENS

F 725X



- Four Ventilé
- 6 programmes
- Inox 60 CM
- Boutons
- 58 Litres
- Chaleur tournante
- Minuterie mécanique
- Porte froide
- Classe Energétique A

- Convection Oven
- 6 Cooking functions
- Stainless Steel 60 CM
- Knobs
- 58 litres capacity
- Convection
- Mecanic timer
- Tangential cooling ventilation
- Energy-efficiency class A



F 720X



- Four Statique
- 5 programmes
- Inox 60 CM
- Boutons
- 58 Litres
- Tourne Broche
- Minuterie
- Porte froide
- Classe Energétique A

- Static Oven
- 5 Cooking functions
- Stainless Steel 60 CM
- Knobs
- 58 litres capacity
- Timed rôtisserie with 2 Forks and 1 Handle
- Mecanic timer
- Tangential cooling ventilation
- Energy-efficiency class A



F 700X



- Four Statique
- 4 programmes
- Inox 60 CM
- Boutons
- 58 Litres
- Minuterie
- Porte froide
- Classe Energétique A

- Static Oven
- 4 Cooking functions
- Stainless Steel 60 CM
- Knobs
- 58 litres capacity
- Mecanic timer
- Tangential cooling ventilation
- Energy-efficiency class A



Logement d'encastrement  
Installation drawing

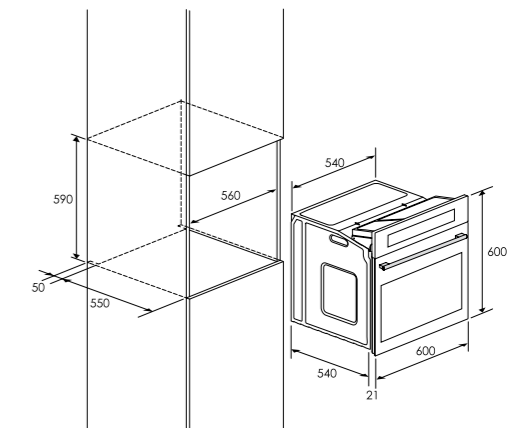

# FOURS ÉLECTRIQUES

## ELECTRIC OVENS

F 725B



- Four Ventilé
- 6 programmes
- Noir 60 CM
- Boutons
- 58 Litres
- Chaleur tournante
- Minuterie mécanique
- Porte froide
- Classe Energétique A

- Convection Oven
- 6 Cooking functions
- Black Glass 60 CM
- Knobs
- 58 litres capacity
- Convection
- Mecanic timer
- Tangential cooling ventilation
- Energy-efficiency class A



F 724X



- Four Multifonction
- 11 programmes
- Inox 60 CM
- Electronique
- 58 Litres
- Chaleur tournante
- Autonettoyant
- Minuterie électronique
- Porte froide
- Porte latérale reversible
- Classe Energétique A

- Multifunction Oven
- 11 Cooking functions
- Stainless Steel 60 CM
- Electronic
- 58 litres capacity
- Convection
- Electronic timer and clock
- Catalytic cleaning cycle
- Tangential cooling ventilation
- Reversible Side door
- Energy-efficiency class A



Logement d'encastrement  
Installation drawing

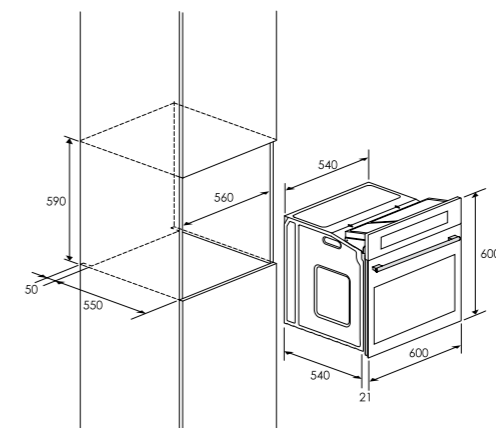

# FOURS ÉLECTRIQUES

## ELECTRIC OVENS

F 722W



- Four Multifonction
- 9 programmes
- Blanc 60 CM
- Boutons
- 58 Litres
- Chaleur tournante
- Minuterie électronique
- Autonettoyant Catalyse
- Porte froide
- Classe Energétique A

- Multifunction Oven
- 9 Cooking functions
- White Glass 60 CM
- Knobs
- 58 litres capacity
- Convection
- Electronic timer and clock
- Catalytic cleaning cycle
- Tangential cooling ventilation
- Energy-efficiency class A



F 721W



- Four Ventilé
- 7 programmes
- Blanc 60 CM
- Boutons
- 58 Litres
- Chaleur tournante
- Minuterie électronique
- Porte froide
- Classe Energétique A

- Convection Oven
- 7 Cooking functions
- White Glass 60 CM
- Knobs
- 58 litres capacity
- Convection
- Electronic timer and clock
- Tangential cooling ventilation
- Energy-efficiency class A



F 725W



- Four Ventilé
- 6 programmes
- Blanc 60 CM
- Boutons
- 58 Litres
- Chaleur tournante
- Minuterie mécanique
- Porte froide
- Classe Energétique A

- Convection Oven
- 6 Cooking functions
- White Glass 60 CM
- Knobs
- 58 litres capacity
- Convection
- Mecanic timer
- Tangential cooling ventilation
- Energy-efficiency class A



Logement d'encastrement  
Installation drawing

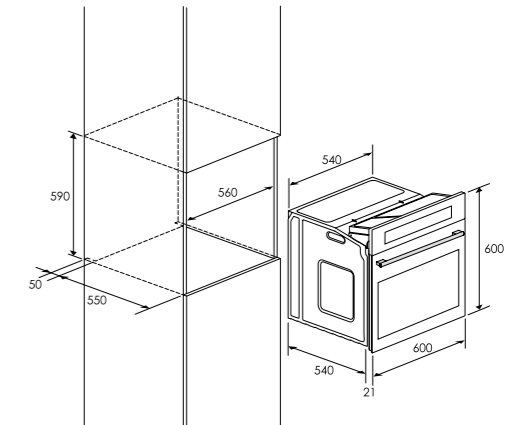



# FOURS À GAZ

## GAS OVENS

F 730X - F 731X



- Four à Gaz Ventilé
- 7 programmes
- Inox 60 CM
- Boutons
- 58 Litres
- Chaleur tournante
- Autonettoyant
- F 730X : Gaz/Gaz
- F 731X : Gaz/Electrique
- Tourne broche
- Minuterie électronique
- Porte froide
- Classe Energétique A

- Fan Gas Oven
- 7 Cooking functions
- Stainless Steel 60 CM
- Knobs
- 58 litres capacity
- Convection
- Catalytic cleaning cycle
- F 730X : Gas/Gas
- F 731X : Gas/Electric
- Timed rôtisserie with 2 Forks and 1 Handle
- Electronic timer
- Tangential cooling ventilation
- Energy-efficiency class A



F 732X - F 733X



- Four à Gaz Ventilé
- 6 programmes
- Inox 60 CM
- Boutons
- 58 Litres
- Chaleur tournante
- F 732X : Gaz/Gaz
- F 733X : Gaz/Electrique
- Tourne broche
- Minuterie
- Porte froide
- Classe Energétique A

- Fan Gas Oven
- 6 Cooking functions
- Stainless Steel 60 CM
- Knobs
- 58 litres capacity
- Convection
- F 732X : Gas/Gas
- F 733X : Gas/Electric
- Timed rôtisserie with 2 Forks and 1 Handle
- Mecanic timer
- Tangential cooling ventilation
- Energy-efficiency class A



F 728X - F 729X



- Four à Gaz Statique
- 5 programmes
- Inox 60 CM
- Boutons
- 58 Litres
- F 728X : Gaz/Gaz
- F 729X : Gaz/Electrique
- Tourne broche
- Minuterie
- Porte froide
- Classe Energétique A

- Static Gas Oven
- 5 Cooking functions
- Stainless Steel 60 CM
- Knobs
- 58 litres capacity
- F 728X : Gas/Gas
- F 729X : Gas/Electric
- Timed rôtisserie with 2 Forks and 1 Handle
- Mecanic timer
- Tangential cooling ventilation
- Energy-efficiency class A



Logement d'encastrement  
Installation drawing

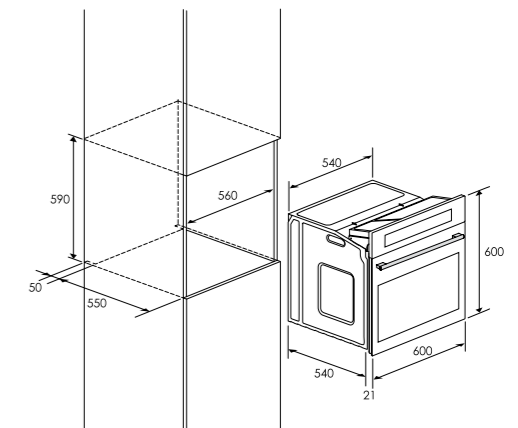

# FOURS 90 CM BIG OVENS

F 795X



- Four Multifonction
- 8 programmes
- Inox 90 CM
- Boutons
- 70 Litres
- Chaleur tournante
- Minuterie électronique
- Autonettoyant Catalyse
- Porte froide
- Classe Energétique A

- Multifunction Oven
- 8 Cooking functions
- Stainless Steel 90 CM
- Knobs
- 70 litres capacity
- Convection
- Electronic timer and clock
- Catalytic cleaning cycle
- Tangential cooling ventilation
- Energy-efficiency class A



F 790X



- Four Ventilé
- 6 programmes
- Inox 90 CM
- Boutons
- 70 Litres
- Chaleur tournante
- Minuterie mécanique
- Porte froide
- Classe Energétique A

- Convection Oven
- 6 Cooking functions
- Stainless Steel 90 CM
- Knobs
- 70 litres capacity
- Convection
- Mecanic timer
- Tangential cooling ventilation
- Energy-efficiency class A



F 793X - F 794X





- Four à Gaz Ventilé
- 7 programmes
- Inox 90 CM
- Boutons
- 75 Litres
- Chaleur tournante
- Autonettoyant
- F 793X : Gaz/Gaz
- F 794X : Gaz/Electrique
- Tourne broche
- Minuterie électronique
- Porte froide
- Classe Energétique A

- Fan Gas Oven
- 7 Cooking functions
- Stainless Steel 90 CM
- Knobs
- 75 litres capacity
- Convection
- Catalytic cleaning cycle
- F 793X : Gas/Gas
- F 793X : Gas/Electric
- Timed rôtisserie with 2 Forks and 1 Handle
- Electronic timer
- Tangential cooling ventilation
- Energy-efficiency class A

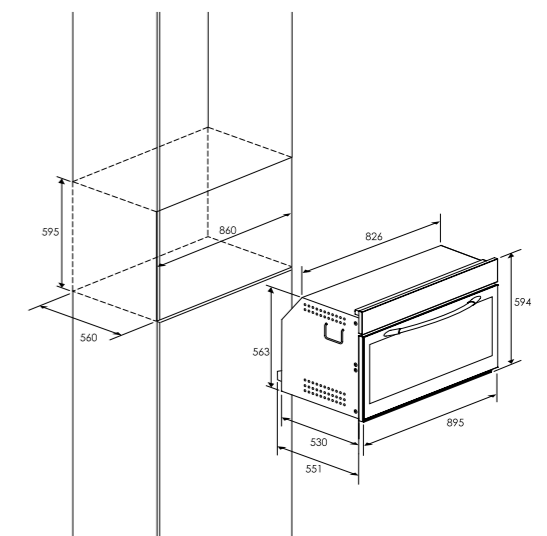
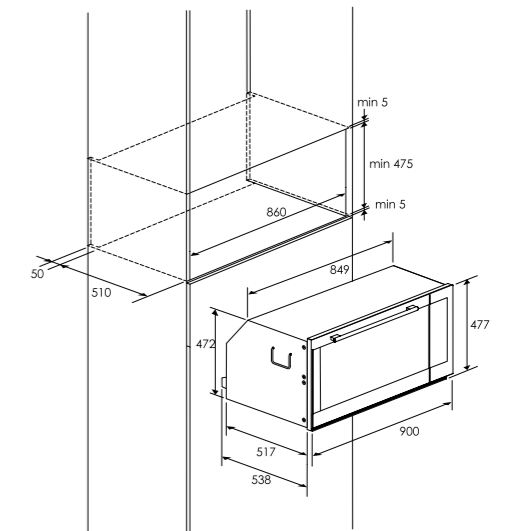

Logement d'encastrement  
Installation drawing



A woman with blonde hair is shown in profile, looking into an open microwave oven. She is holding a white bowl. The microwave is silver and black, with a digital display showing '10:00'. The background is a bright, clean kitchen.

## MICRO-ONDES MICRO-WAVES

Les micro-ondes FOCUS, alliance de simplicité, de rapidité et de haute technologie. Certains vous offrent toute la simplicité que vous recherchez.

Ils remplissent à merveille leur mission de micro-ondes et leur fonction grill garantit le dorage parfait de vos préparations.

D'autres vous séduiront par leur grande polyvalence. Permettant de réaliser cuissons combinées, micro-ondes ou traditionnelles, ces instruments de précision vous feront gagner un temps précieux.

*Microwaves FOCUS, simplicity alliance, speed and high technology. Some offer the simplicity you want.*

*They fulfill their mission perfectly microwave and grill function ensures perfect browning your preparations.*

*Others seduce you with their versatility. For performing combined cooking, microwave or traditional, these precision instruments will save you valuable time.*



# MODES DE CUISSON

## COOKING METHODS



fonction «ON/OFF» et fonction «clé (child lock)».  
 "ON/ OFF" and "key (child lock)" function.



La lampe reste toujours allumée durant le fonctionnement dans les modalités microondes et pour une épargne énergétique, elle est gérée par le système, dans les autres modalités .  
 The light is always on during operation in microwave mode and, to save energy, is managed by the system in the other modes.



Avec ce type de cuisson, un ventilateur situé sur la partie postérieure fait circuler d'air chaud à l'intérieur du micro-ondes, en le distribuant de façon uniforme. La cuisson a lieu plus rapidement que la cuisson conventionnelle. Le système est approprié à la cuisson sur plusieurs niveaux et même pour des aliments de nature différente (poisson, viande etc.).

In this type of cooking, a fan located in the rear part circulates warm air inside the micro-waves, distributing it uniformly.  
 This cooks food faster than conventional cooking. This system is good for cooking on several shelves and even for different types of foods (fish, meat, etc.).



Type de cuisson pour griller ou dorer des aliments. La grille avec les aliments à cuire doit être introduite sur le 2e ou 3e niveau du dessous. Préchauffer pendant au moins 2 minutes avant d'introduire le plat.

Type of cooking for grilling or browning foods. The grill with the food to be cooked is placed in the 2nd or 3rd position from the bottom. Pre-heat for at least 2 minutes before putting in the dish.



Décongélation au temps  
 Time defrosting



Décongélation au poids  
 Weight defrosting



Micro-ondes  
 Microwaves



Micro-ondes combiné avec la cuisson au Grill  
 Microwaves combined with grill cooking



Micro-ondes combiné avec la cuisson ventilée  
 Microwaves combined with ventilated cooking



Accès aux recettes pré-établies  
 Access to preset recipes



Micro / Grill / Combi  
 Micro / Grill / Combi



Poids / Heure Décongélation  
 Weigh / Time Defrost



Minuterie  
 Timer / Clock



Arrêt  
 Stop / Clear



Démarrer  
 Start

# MICRO-ONDES

## MICROWAVES

### QUADRA 46



- Micro-ondes / Four Combiné
- 11 fonctions
- Inox 45 CM
- Commandes touches tactiles
- Éclairage halogène
- 40 Litres
- Recettes préinstallées
- Chaleur tournante
- Timer electronic
- Micro ondes, Grill, Four
- Cavité Inox

- Microwave / Oven combined
- 11 functions
- Stainless steel 45 CM
- Panel with sensor controls
- Halogen lighting
- 40 Litres
- Functions Pre-selected
- Forced-air cooking
- Electronic timer and clock
- Microwave, Grill, Oven
- Cooking chamber in Stainless



### FILO 46



- Micro-ondes / Four Combiné
- 11 fonctions
- Inox & Noir 45 CM
- Commandes touches tactiles
- Éclairage halogène
- 40 Litres
- Recettes préinstallées
- Chaleur tournante
- Timer electronic
- Micro ondes, Grill, Four
- Cavité Inox

- Microwave / Oven combined
- 11 functions
- Stainless steel & Black Glass 45 CM
- Panel with sensor controls
- Halogen lighting
- 40 Litres
- Functions Pre-selected
- Forced-air cooking
- Electronic timer and clock
- Microwave, Grill, Oven
- Cooking chamber in Stainless



### SOFT 46



- Micro-ondes / Four Combiné
- 11 fonctions
- Noir 45 CM
- Commandes touches tactiles
- Éclairage halogène
- 40 Litres
- Recettes préinstallées
- Chaleur tournante
- Timer electronic
- Micro ondes, Grill, Four
- Cavité Inox

- Microwave / Oven combined
- 11 functions
- Black Glass 45 CM
- Panel with sensor controls
- Halogen lighting
- 40 Litres
- Functions Pre-selected
- Forced-air cooking
- Electronic timer and clock
- Microwave, Grill, Oven
- Cooking chamber in Stainless



### Logement d'encastrement

#### Installation drawing

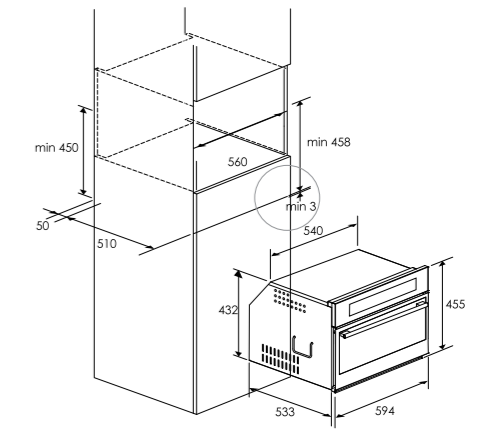

# MICRO-ONDES

## MICROWAVES

### QUADRA 50



- Micro-ondes Grill
- Porte en vitre
- Inox 39 CM
- Cavité Inox
- 5 niveaux de puissance
- 25 Litres
- Verrouillage enfant
- La fonction de dégivrage en poids
- Contrôle Tactile
- Ouverture du porte électronique

- Microwave Grill
- Glass Door
- Stainless steel 39 CM
- Stainless steel oven interior
- 5 Power levels
- 25 Litres
- Child Lock
- Defrost function by weight
- Touch Control
- Electronic open door



### SOFT 40



- Micro-ondes Grill
- Porte en vitre
- Noir 39 CM
- Cavité Inox
- 5 niveaux de puissance
- 25 Litres
- Verrouillage enfant
- La fonction de dégivrage en poids
- Contrôle Tactile
- Ouverture du porte électronique

- Microwave Grill
- Glass Door
- Black Glass 39 CM
- Stainless steel oven interior
- 5 Power levels
- 25 Litres
- Child Lock
- Defrost function by weight
- Touch Control
- Electronic open door



### FILLO-QUADRA 15



- Tiroir-chauffe Plats
- Ouverture push / pull
- Inox 15 CM
- Intérieur Inox
- Fonction de dégivrage
- Façade froide
- La surface du plateau en verre noir
- Ventilé
- Voyant de fonctionnement
- Minuterie mécanique
- Thermostat réglable de 40 ° C à 70 ° C
- Guides télescopiques

- Food warmer drawer
- Opening push/pull
- Stainless steel 15 CM
- Stainless steel interior
- Defrost function
- Cold front
- Shelf surface in black glass
- Ventilated
- Operating indicator light
- Power-off timer
- Thermostat adjustable from 40 ° C to 70 ° C
- Telescopic guides for sliding opening

### Logement d'encastrement

#### Installation drawing

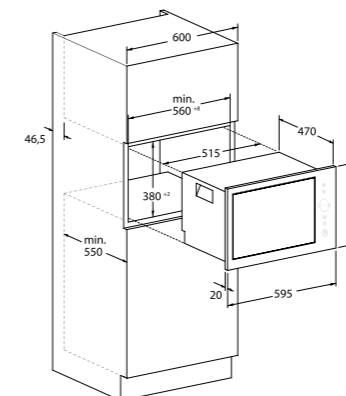

### SOFT 15



- Tiroir-chauffe Plats
- Ouverture push / pull
- Noir 15 CM
- Intérieur Inox
- Fonction de dégivrage
- Façade froide
- La surface du plateau en verre noir
- Ventilé
- Voyant de fonctionnement
- Minuterie mécanique
- Thermostat réglable de 40 ° C à 70 ° C
- Guides télescopiques

- Food warmer drawer
- Opening push/pull
- Black Glass 15 CM
- Stainless steel interior
- Defrost function
- Cold front
- Shelf surface in black glass
- Ventilated
- Operating indicator light
- Power-off timer
- Thermostat adjustable from 40 ° C to 70 ° C
- Telescopic guides for sliding opening

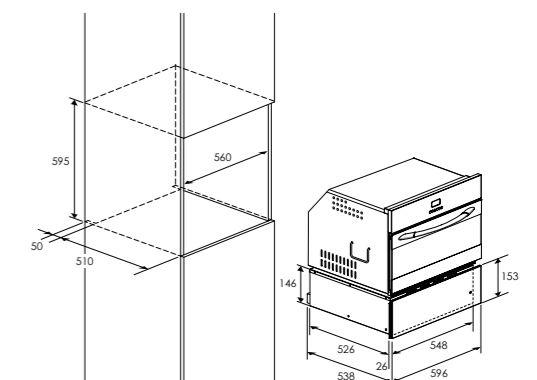

# MICRO-ONDES

## MICROWAVES

F 25X



- Micro-ondes Grill
- Porte en vitre
- Inox 39 CM
- Cavité Inox
- 5 niveaux de puissance
- 25 Litres
- Verrouillage enfant
- La fonction de dégivrage en poids
- Contrôle électronique

- Microwave Grill
- Glass Door
- Stainless steel & Black Glass 39 CM
- Stainless steel oven interior
- 5 Power levels
- 25 Litres
- Child Lock
- Defrost function by weight
- Electronic control



F 23X



- Micro-ondes Grill
- Porte en vitre
- Inox 39 CM
- Cavité Inox
- 5 niveaux de puissance
- 20 Litres
- Verrouillage enfant
- La fonction de dégivrage en poids
- Contrôle électronique

- Microwave Grill
- Glass Door
- Stainless steel & Black Glass 39 CM
- Stainless steel oven interior
- 5 Power levels
- 20 Litres
- Child Lock
- Defrost function by weight
- Electronic control



F 24B



- Micro-ondes Grill
- Porte en vitre
- Noir 39 CM
- Cavité Inox
- 5 niveaux de puissance
- 20 Litres
- Contrôle mécanique

- Microwave Grill
- Glass Door
- Black 39 CM
- Stainless steel oven interior
- 5 Power levels
- 20 Litres
- Mecanic control



Logement d'encastrement  
Installation drawing

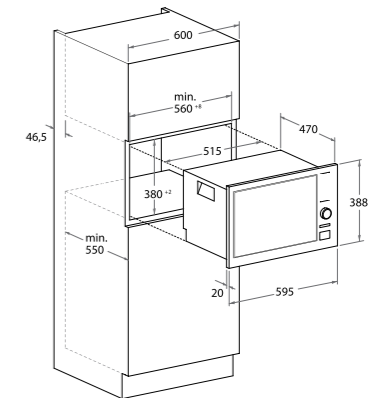



## PLAQUES DE CUISSONS

### HOBS

La cuisson est la phase la plus délicate en cuisine, surtout lorsqu'il faut concocter plusieurs préparations en même temps qui exigent des températures différentes. Le choix de la table de cuisson et les fonctionnalités qu'elle offre permettront d'exalter la magie de votre créativité et vos performances culinaires. Les tables de cuisson FOCUS vous offrent d'incroyables possibilités d'exprimer toute votre créativité et de réaliser des performances dignes des plus grands chefs, chez vous.

*Cooking is the most delicate phase in the kitchen, especially when you cook several preparations at the same time that require different temperatures. The choice of the hob and the features will exalt the magic of your creativity and culinary performance. FOCUS hobs offer incredible opportunities to express your creativity and realize performance worthy of the greatest chefs, home.*



# PLAQUES DE CUISSONS

## HOBS

QUADRA 62



- Inox 62 CM
- 4 Brûleurs à gaz, l'un double Couronnes
- Flamme stabilisée
- Grilles et chapeaux de brûleurs en fonte
- Allumage Automatique
- Commandes frontales
- Sécurité gaz sur chaque brûleur

- *Stainless steel 62 CM gas hob*
- *4 gas burners, including one Double Crown burner*
- *Stabilized flame*
- *Cast Iron Grids and burner caps*
- *Automatic ignition*
- *Front metal knobs*
- *Flame failure device on all burners*

QUADRA 76



- Inox 76 CM
- 5 Brûleurs à gaz, l'un Triple Couronnes
- Flamme stabilisée
- Grilles et chapeaux de brûleurs en fonte
- Allumage Automatique
- Commandes frontales
- Sécurité gaz sur chaque brûleur

- *Stainless steel 76 CM gas hob*
- *5 gas burners, including one Triple Crown burner*
- *Stabilized flame*
- *Cast Iron Grids and burner caps*
- *Automatic ignition*
- *Front metal knobs*
- *Flame failure device on all burners*

QUADRA 92



- Inox 92 CM
- 5 Brûleurs à gaz, l'un Triple Couronnes
- Flamme stabilisée
- Grilles et chapeaux de brûleurs en fonte
- Allumage Automatique
- Commandes frontales
- Sécurité gaz sur chaque brûleur

- *Stainless steel 92 CM gas hob*
- *5 gas burners, including one Triple Crown burner*
- *Stabilized flame*
- *Cast Iron Grids and burner caps*
- *Automatic ignition*
- *Front metal knobs*
- *Flame failure device on all burners*

Logement d'encastrement  
*Installation drawing*

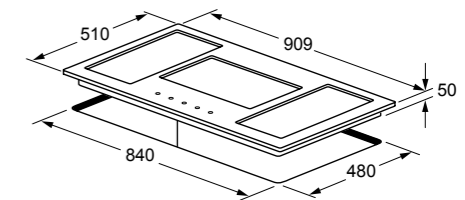
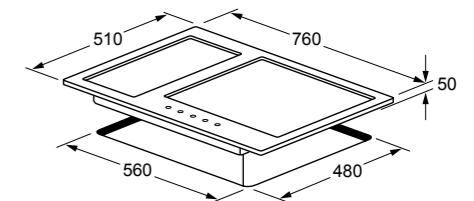
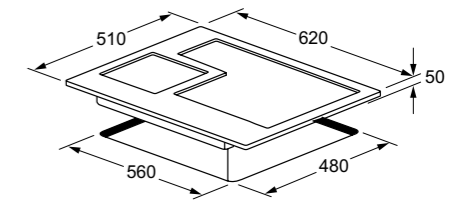

# PLAQUES DE CUISSONS

## HOBS

### QUADRA 60



- Inox 60 CM
- 4 Bruleurs à gaz, l'un double Couronnes
- Flamme stabilisée
- Grilles et chapeaux de brûleurs en fonte
- Allumage Automatique
- Commandes frontales
- Sécurité gaz sur chaque brûleur

- *Stainless steel 60 CM gas hob*
- *4 gas burners, including one Double Crown burner*
- *Stabilized flame*
- *Cast Iron Grids and burner caps*
- *Automatic ignition*
- *Front metal knobs*
- *Flame failure device on all burners*

### QUADRA 75



- Inox 75 CM
- 5 Bruleurs à gaz, l'un Triple Couronnes
- Flamme stabilisée
- Grilles et chapeaux de brûleurs en fonte
- Allumage Automatique
- Commandes frontales
- Sécurité gaz sur chaque brûleur

- *Stainless steel 75 CM gas hob*
- *5 gas burners, including one Triple Crown burner*
- *Stabilized flame*
- *Cast Iron Grids and burner caps*
- *Automatic ignition*
- *Front metal knobs*
- *Flame failure device on all burners*

### QUADRA 90



- Inox 90 CM
- 5 Bruleurs à gaz, l'un Triple Couronnes
- Flamme stabilisée
- Grilles et chapeaux de brûleurs en fonte
- Allumage Automatique
- Commandes frontales
- Sécurité gaz sur chaque brûleur

- *Stainless steel 90 CM gas hob*
- *5 gas burners, including one Triple Crown burner*
- *Stabilized flame*
- *Cast Iron Grids and burner caps*
- *Automatic ignition*
- *Front metal knobs*
- *Flame failure device on all burners*

### Logement d'encastrement

#### Installation drawing

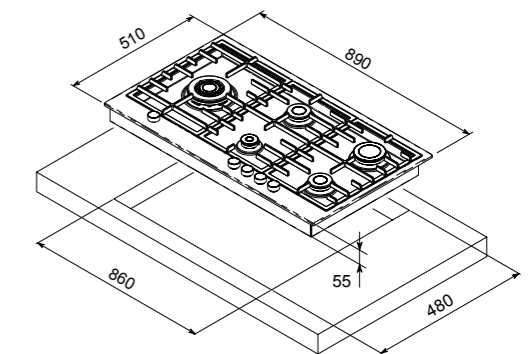
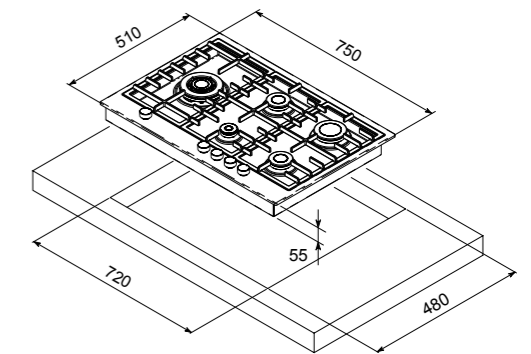
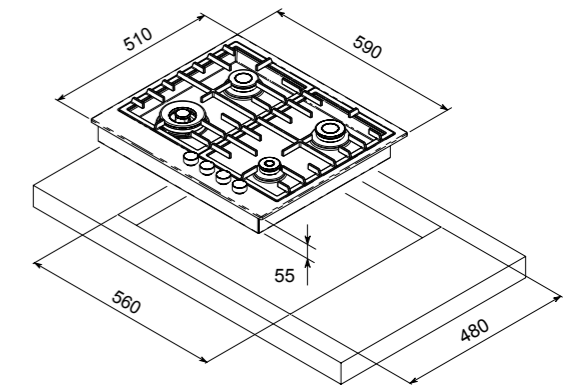

# PLAQUES DE CUISSONS

## HOBS

FILO 60



- Filotop Inox 60 CM
- 4 Brûleurs à gaz, l'un double Couronnes
- Flamme stabilisée
- Grilles et chapeaux de brûleurs en fonte
- Allumage Automatique
- Commandes frontales
- Sécurité gaz sur chaque brûleur

- *Filotop Stainless steel 60 CM gas hob*
- *4 gas burners, including one Double Crown burner*
- *Stabilized flame*
- *Cast Iron Grids and burner caps*
- *Automatic ignition*
- *Front metal knobs*
- *Flame failure device on all burners*

FILO 75



- Filotop Inox 75 CM
- 5 Brûleurs à gaz, l'un Triple Couronnes
- Flamme stabilisée
- Grilles et chapeaux de brûleurs en fonte
- Allumage Automatique
- Commandes frontales
- Sécurité gaz sur chaque brûleur

- *Filotop Stainless steel 75 CM gas hob*
- *5 gas burners, including one Triple Crown burner*
- *Stabilized flame*
- *Cast Iron Grids and burner caps*
- *Automatic ignition*
- *Front metal knobs*
- *Flame failure device on all burners*

FILO 90



- Filotop Inox 90 CM
- 5 Brûleurs à gaz, l'un Triple Couronnes
- Flamme stabilisée
- Grilles et chapeaux de brûleurs en fonte
- Allumage Automatique
- Commandes frontales
- Sécurité gaz sur chaque brûleur

- *Filotop Stainless steel 90 CM gas hob*
- *5 gas burners, including one Triple Crown burner*
- *Stabilized flame*
- *Cast Iron Grids and burner caps*
- *Automatic ignition*
- *Front metal knobs*
- *Flame failure device on all burners*

Logement d'encastrement  
*Installation drawing*

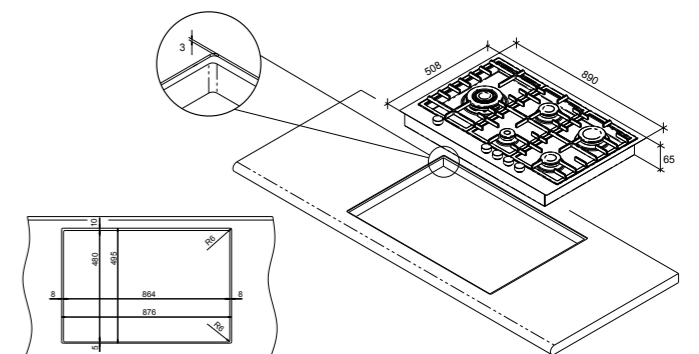
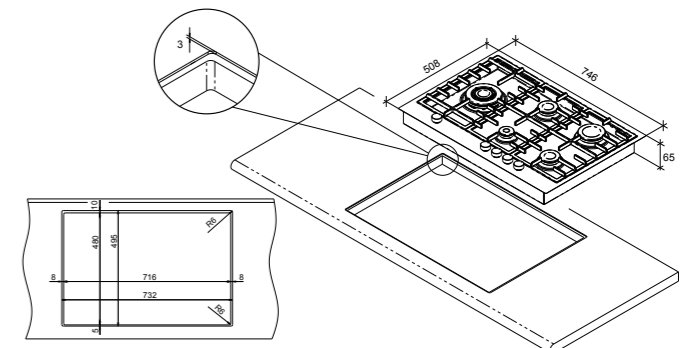
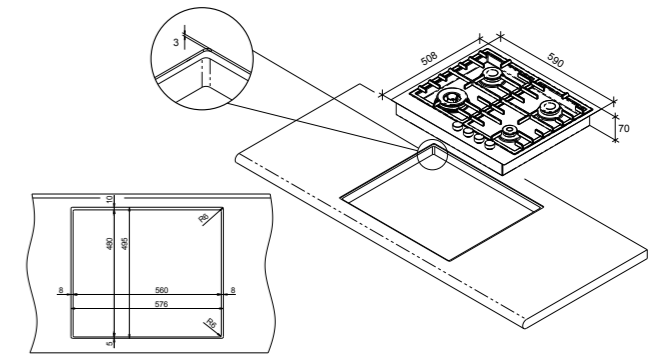

# PLAQUES DE CUISSONS

## HOBS

SOFT 60



- Vitro noir 60 CM
- 4 Bruleurs à gaz, l'un Triple Couronnes
- Flamme stabilisée
- Grilles et chapeaux de brûleurs en fonte
- Allumage Automatique
- Commandes frontales
- Sécurité gaz sur chaque brûleur
- Profils Aluminium

- *Black Glass 60 CM gas hob*
- *4 gas burners, including one Triple Crown burner*
- *Stabilized flame*
- *Cast Iron Grids and burner caps*
- *Automatic ignition*
- *Front metal knobs*
- *Flame failure device on all burners*
- *Aluminium profiles*

SOFT 75

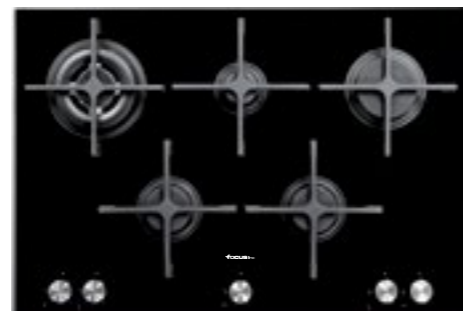

- Vitro noir 75 CM
- 5 Bruleurs à gaz, l'un Triple Couronnes
- Flamme stabilisée
- Grilles et chapeaux de brûleurs en fonte
- Allumage Automatique
- Commandes frontales
- Sécurité gaz sur chaque brûleur
- Profils Aluminium

- *Black Glass 75 CM gas hob*
- *5 gas burners, including one Triple Crown burner*
- *Stabilized flame*
- *Cast Iron Grids and burner caps*
- *Automatic ignition*
- *Front metal knobs*
- *Flame failure device on all burners*
- *Aluminium profiles*

SOFT 90



- Vitro noir 90 CM
- 5 Bruleurs à gaz, l'un Triple Couronnes
- Flamme stabilisée
- Grilles et chapeaux de brûleurs en fonte
- Commandes touches tactiles
- Allumage Automatique
- Commandes frontales
- Sécurité gaz sur chaque brûleur
- Profils Aluminium

- *Black Glass 90 CM gas hob*
- *5 gas burners, including one Triple Crown burner*
- *Stabilized flame*
- *Cast Iron Grids and burner caps*
- *Touch Control panel*
- *Automatic ignition*
- *Flame failure device on all burners*
- *Aluminium profiles*

Logement d'encastrement  
Installation drawing

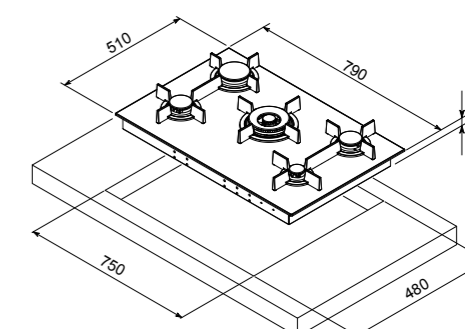
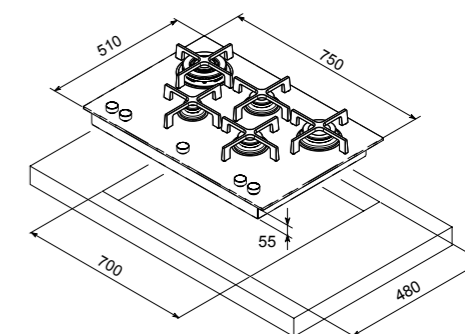
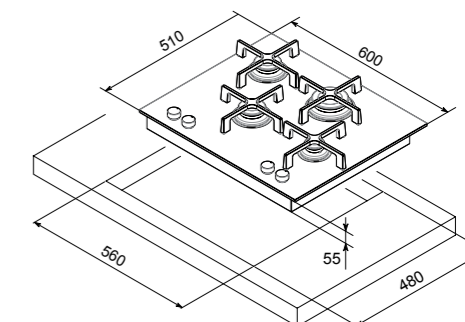

# PLAQUES DE CUISSONS

## HOBS

### QUADRA 112



- Inox 112 CM
  - 4 Bruleurs à gaz, l'un Triple Couronnes
  - Flamme stabilisée
  - Grilles et chapeaux de brûleurs en fonte
  - Allumage Automatique
  - Commandes frontales
  - Sécurité gaz sur chaque brûleur
- *Stainless steel 112 CM gas hob*
  - *4 gas burners, including one Triple Crown burner*
  - *Stabilized flame*
  - *Cast Iron Grids and burner caps*
  - *Automatic ignition*
  - *Front metal knobs*
  - *Flame failure device on all burners*

### FILO 124



- Filotop Inox 110 CM
  - 4 Bruleurs à gaz, l'un Triple Couronnes
  - Flamme stabilisée
  - Grilles et chapeaux de brûleurs en fonte
  - Allumage Automatique
  - Commandes frontales
  - Sécurité gaz sur chaque brûleur
- *Filotop Stainless steel 110 CM gas hob*
  - *4 gas burners, including one Triple Crown burner*
  - *Stabilized flame*
  - *Cast Iron Grids and burner caps*
  - *Automatic ignition*
  - *Front metal knobs*
  - *Flame failure device on all burners*

### SOFT 104



- Vitro noir 100 CM
  - 4 Bruleurs à gaz, l'un Triple Couronnes
  - Flamme stabilisée
  - Grilles et chapeaux de brûleurs en fonte
  - Allumage Automatique
  - Commandes frontales
  - Sécurité gaz sur chaque brûleur
  - Profils Aluminium
- *Black Glass 100 CM gas hob*
  - *4 gas burners, including one Triple Crown burner*
  - *Stabilized flame*
  - *Cast Iron Grids and burner caps*
  - *Automatic ignition*
  - *Front metal knobs*
  - *Flame failure device on all burners*
  - *Aluminium profiles*

### Logement d'encastrement

#### Installation drawing

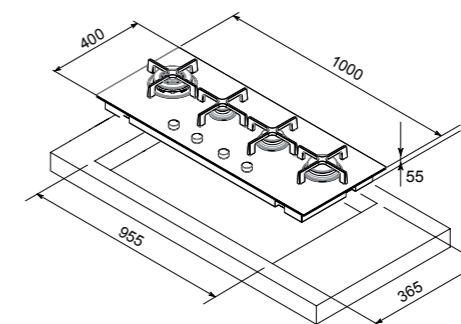
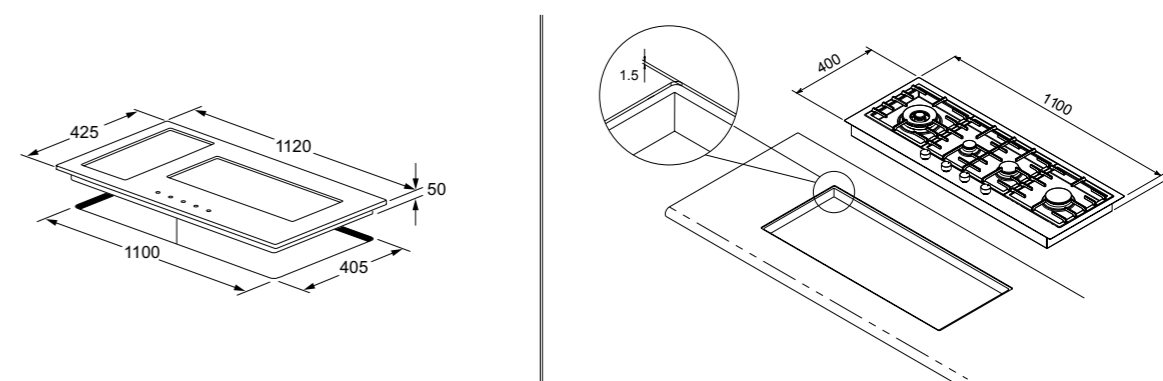

# PLAQUES DE CUISSONS

## HOBS

SOFT 31



- Domino Vitro noir 30 CM
- Un Bruleur à gaz Triple Couronnes
- Flamme stabilisée
- Grilles et chapeaux de brûleurs en fonte
- Allumage Automatique
- Commandes frontales
- Sécurité gaz sur chaque brûleur
- Profils Aluminium

- *Domino Black Glass 30 CM gas hob*
- *One Triple Crown burner gas*
- *Stabilized flame*
- *Cast Iron Grids and burner caps*
- *Automatic ignition*
- *Front metal knobs*
- *Flame failure device on all burners*
- *Aluminium profiles*

SOFT 32



- Domino Vitro noir 30 CM
- 2 Bruleurs à gaz
- Flamme stabilisée
- Grilles et chapeaux de brûleurs en fonte
- Allumage Automatique
- Commandes frontales
- Sécurité gaz sur chaque brûleur
- Profils Aluminium

- *Domino Black Glass 30 CM gas hob*
- *2 burners gas*
- *Stabilized flame*
- *Cast Iron Grids and burner caps*
- *Automatic ignition*
- *Front metal knobs*
- *Flame failure device on all burners*
- *Aluminium profiles*

SOFT 33



- Domino Vitro Céramique noir 30 CM
- 2 Foyers radiant Hiilight
- 2100 W & 1200 W
- Contrôles sensitifs
- Profils Aluminium

- *Domino Ceramic 30 CM*
- *2 Fireplaces radiant Hiilight*
- *2100 W & 1200 W*
- *Touch Control panel*
- *Aluminium profiles*

SOFT 38

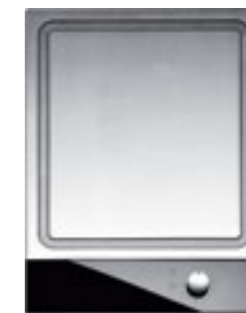

- Domino Teppanyaki 38 CM
- Inox
- Commande frontale

- *Domino Teppanyaki 38 CM*
- *Stainless steel*
- *Front metal knob*

### Logement d'encastrement

*Installation drawing*

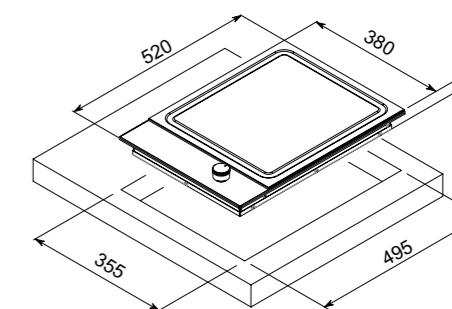
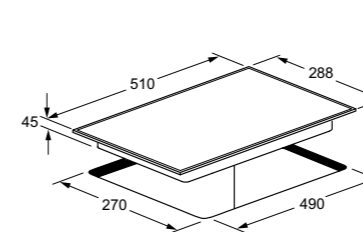
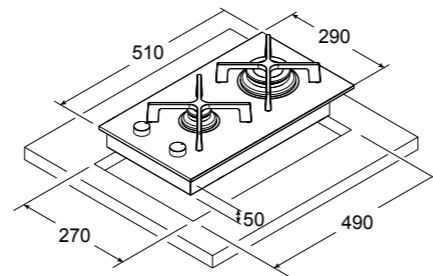
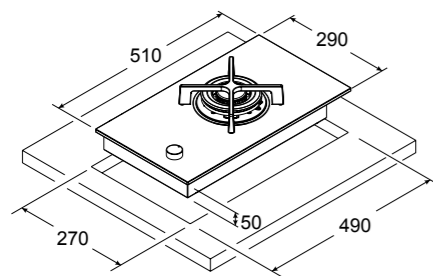



# PLAQUES DE CUISSONS

## HOBS

---

### TORNADO

---



- Vitro inductin 60 CM
- 4 Foyers électriques
- Contrôles sensitifs
- Sécurité enfant
- Indicateurs de chaleur
- Profils Aluminium

- 
- Inductin Hob 60 CM
  - 4 Electric Fireplaces
  - Contrôles sensitifs
  - Child lock
  - Residual heat indicators
  - Aluminium profiles
- 

---

### COMO

---



- Vitro céramique 60 CM
- 4 Foyers électriques
- Contrôles sensitifs
- Sécurité enfant
- Indicateurs de chaleur
- Profils Aluminium

- 
- Ceramic Hob 60 CM
  - 4 Electric Fireplaces
  - Contrôles sensitifs
  - Child lock
  - Residual heat indicators
  - Aluminium profiles
- 

Logement d'encastrement  
*Installation drawing*

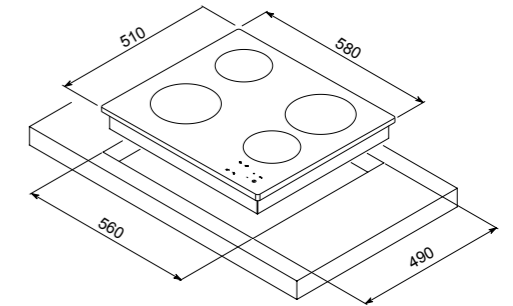
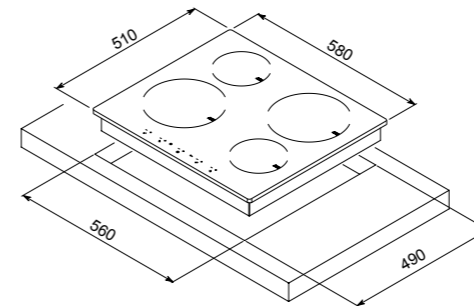

# PLAQUES DE CUISSONS

## HOBS

F 804B



- Vitro noir 60 CM
- Cadre Aluminium
- 4 Bruleurs à gaz
- Flamme stabilisée
- Grilles et chapeaux de brûleurs en fonte
- Allumage Automatique
- Commandes frontales
- Sécurité gaz sur chaque brûleur

- *Black Glass 60 CM gas hob*
- *Aluminium Frame*
- *4 gas burners*
- *Stabilized flame*
- *Cast Iron Grids and burner caps*
- *Automatic ignition*
- *Front metal knobs*
- *Flame failure device on all burners*

F 811B



- Vitro noir 75 CM
- Cadre Aluminium
- 5 Bruleurs à gaz, l'un Triple Couronnes
- Flamme stabilisée
- Grilles et chapeaux de brûleurs en fonte
- Allumage Automatique
- Commandes frontales
- Sécurité gaz sur chaque brûleur

- *Black Glass 75 CM gas hob*
- *Aluminium Frame*
- *5 gas burners, including one Triple Crown burner*
- *Stabilized flame*
- *Cast Iron Grids and burner caps*
- *Automatic ignition*
- *Front metal knobs*
- *Flame failure device on all burners*

F 8119B



- Vitro noir 90 CM
- Cadre Aluminium
- 5 Bruleurs à gaz, l'un Triple Couronnes
- Flamme stabilisée
- Grilles et chapeaux de brûleurs en fonte
- Allumage Automatique
- Commandes frontales
- Sécurité gaz sur chaque brûleur

- *Black Glass 90 CM gas hob*
- *Aluminium Frame*
- *5 gas burners, including one Triple Crown burner*
- *Stabilized flame*
- *Cast Iron Grids and burner caps*
- *Automatic ignition*
- *Front metal knobs*
- *Flame failure device on all burners*

Logement d'encastrement  
*Installation drawing*

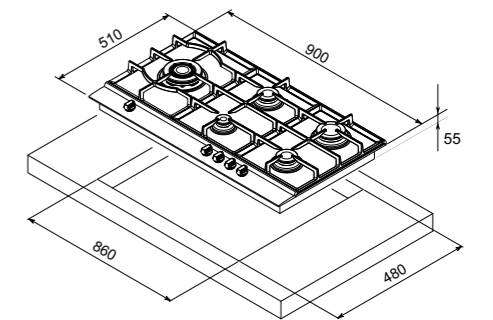
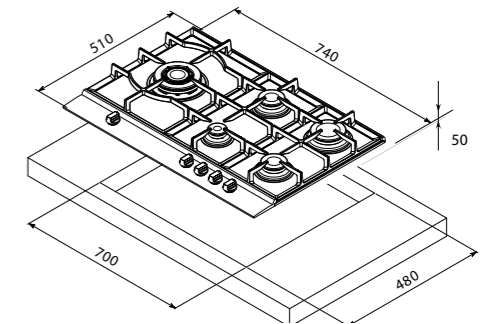
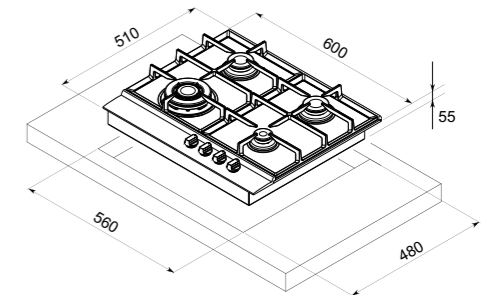

# PLAQUES DE CUISSONS

## HOBS

F 815B

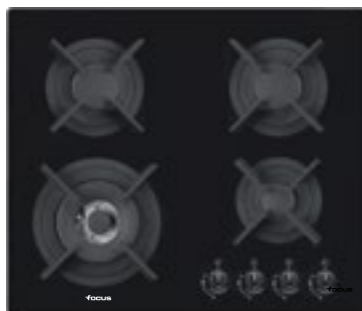

- Vitro noir 60 CM
- 4 Bruleurs à gaz, l'un Triple Couronnes
- Flamme stabilisée
- Grilles et chapeaux de brûleurs en fonte
- Allumage Automatique
- Commandes frontales

- *Black Glass 60 CM gas hob*
- *4 gas burners, including one Double Crown burner*
- *Stabilized flame*
- *Cast Iron Grids and burner caps*
- *Automatic ignition*
- *Front knobs*

F 817B



- Vitro noir 70 CM
- 5 Bruleurs à gaz, l'un Triple Couronnes
- Flamme stabilisée
- Grilles et chapeaux de brûleurs en fonte
- Allumage Automatique
- Commandes frontales

- *Black Glass 70 CM gas hob*
- *5 gas burners, including one Double Crown burner*
- *Stabilized flame*
- *Cast Iron Grids and burner caps*
- *Automatic ignition*
- *Front knobs*

F 8179B



- Vitro noir 90 CM
- 5 Bruleurs à gaz, l'un Triple Couronnes
- Flamme stabilisée
- Grilles et chapeaux de brûleurs en fonte
- Allumage Automatique
- Commandes frontales

- *Black Glass 90 CM gas hob*
- *5 gas burners, including one Double Crown burner*
- *Stabilized flame*
- *Cast Iron Grids and burner caps*
- *Automatic ignition*
- *Front knobs*

Logement d'encastrement  
*Installation drawing*

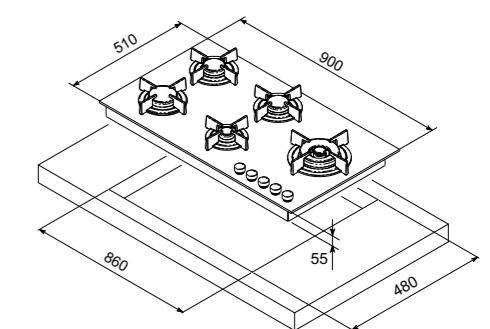
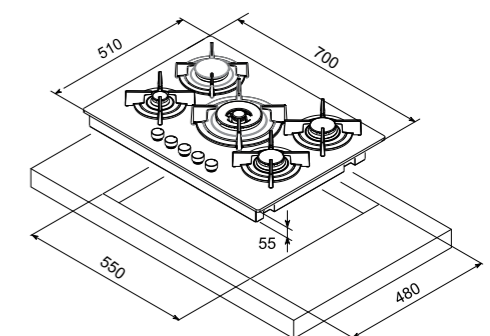
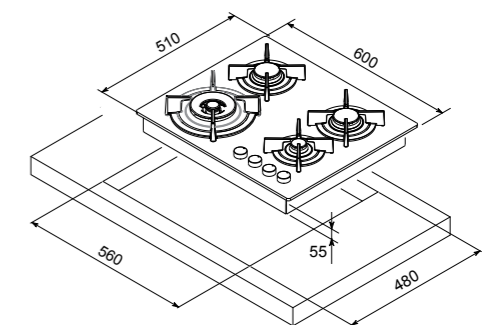

# PLAQUES DE CUISSONS

## HOBBS

F 809B



- Vitro noir 60 CM
- 4 Bruleurs à gaz
- Flamme stabilisée
- Grilles et chapeaux de brûleurs émaillés
- Allumage Automatique
- Commandes frontales

- *Black Glass 60 CM gas hob*
- *4 gas burners*
- *Stabilized flame*
- *Enamelled Grids and burner caps*
- *Automatic ignition*
- *Front knobs*

F 810B



- Vitro noir 70 CM
- 4 Bruleurs à gaz
- Flamme stabilisée
- Grilles et chapeaux de brûleurs émaillés
- Allumage Automatique
- Commandes frontales

- *Black Glass 70 CM gas hob*
- *4 gas burners*
- *Stabilized flame*
- *Enamelled Grids and burner caps*
- *Automatic ignition*
- *Front knobs*

F 809W

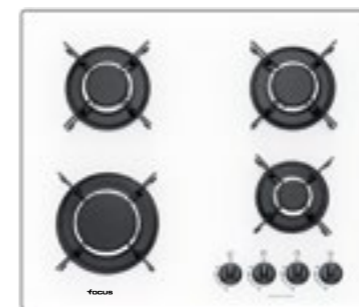

- Vitro blanc 60 CM
- 4 Bruleurs à gaz
- Flamme stabilisée
- Grilles et chapeaux de brûleurs émaillés
- Allumage Automatique
- Commandes frontales

- *White Glass 60 CM gas hob*
- *4 gas burners*
- *Stabilized flame*
- *Enamelled Grids and burner caps*
- *Automatic ignition*
- *Front knobs*

F 810W

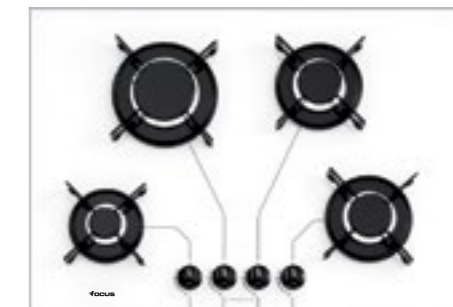

- Vitro blanc 70 CM
- 4 Bruleurs à gaz
- Flamme stabilisée
- Grilles et chapeaux de brûleurs émaillés
- Allumage Automatique
- Commandes frontales

- *White Glass 70 CM gas hob*
- *4 gas burners*
- *Stabilized flame*
- *Enamelled Grids and burner caps*
- *Automatic ignition*
- *Front metal knobs*

### Logement d'encastrement

#### Installation drawing

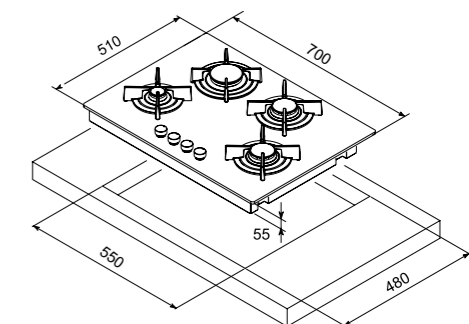
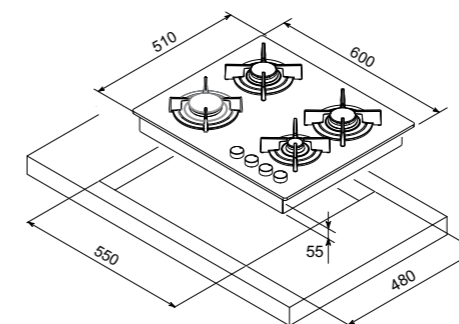
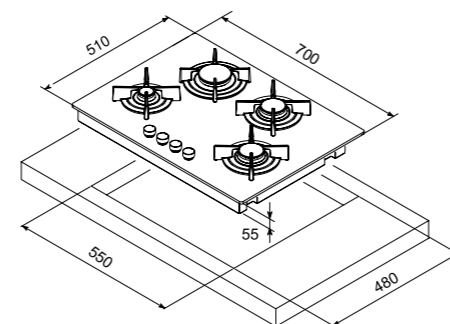
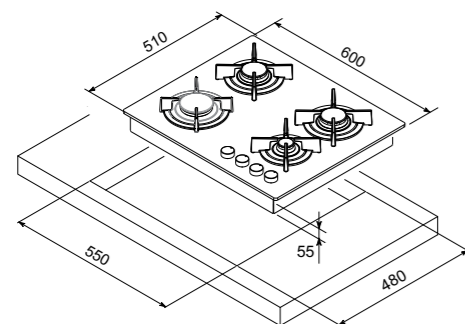

# PLAQUES DE CUISSONS

## HOBS

F 809G

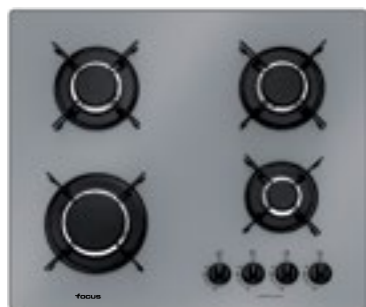

- Vitro Gris 60 CM
- 4 Bruleurs à gaz
- Flamme stabilisée
- Grilles et chapeaux de brûleurs émaillés
- Allumage Automatique
- Commandes frontales

- Silver Glass 60 CM gas hob
- 4 gas burners
- Stabilized flame
- Enamelled Grids and burner caps
- Automatic ignition
- Front knobs

F 810G



- Vitro Gris 70 CM
- 4 Bruleurs à gaz
- Flamme stabilisée
- Grilles et chapeaux de brûleurs émaillés
- Allumage Automatique
- Commandes frontales

- Silver Glass 70 CM gas hob
- 4 gas burners
- Stabilized flame
- Enamelled Grids and burner caps
- Automatic ignition
- Front knobs

F 809S

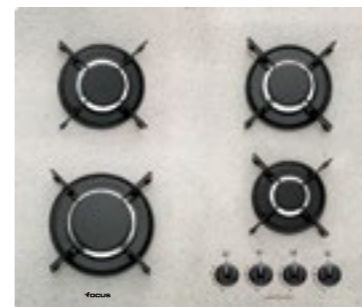

- Vitro Granite 60 CM
- 4 Bruleurs à gaz
- Flamme stabilisée
- Grilles et chapeaux de brûleurs émaillés
- Allumage Automatique
- Commandes frontales

- Granit Glass 60 CM gas hob
- 4 gas burners
- Stabilized flame
- Enamelled Grids and burner caps
- Automatic ignition
- Front knobs

F 810S

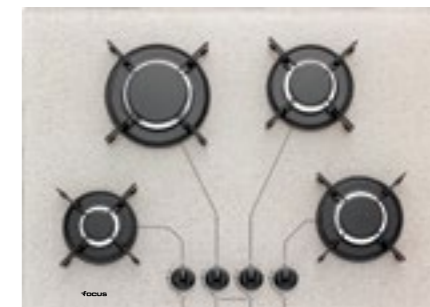

- Vitro Granite 70 CM
- 4 Bruleurs à gaz
- Flamme stabilisée
- Grilles et chapeaux de brûleurs émaillés
- Allumage Automatique
- Commandes frontales

- Granit Glass 70 CM gas hob
- 4 gas burners
- Stabilized flame
- Enamelled Grids and burner caps
- Automatic ignition
- Front knobs

Logement d'encastrement  
Installation drawing

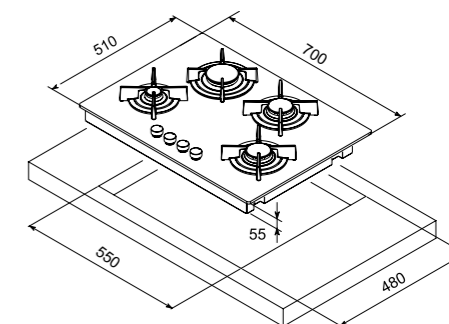
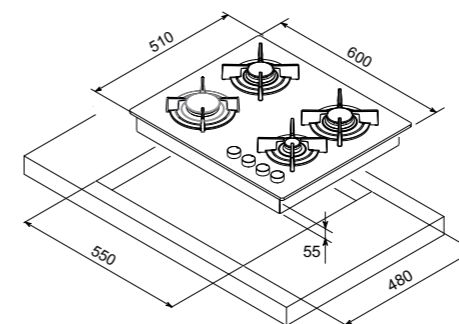
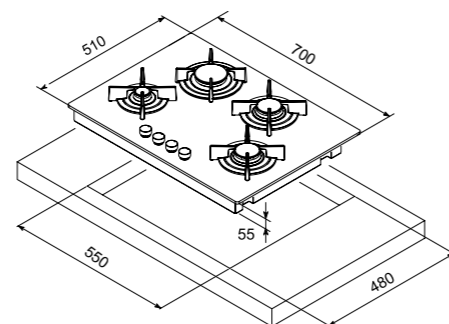
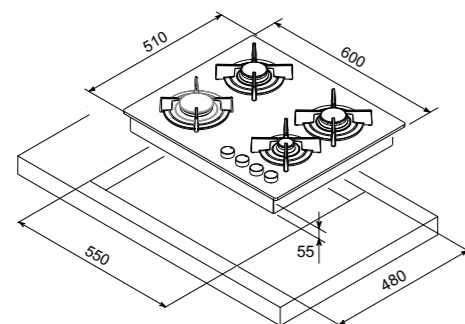

# PLAQUES DE CUISSONS

## HOBS

F 809SX



- Vitro Stopsol 60 CM
- 4 Bruleurs à gaz
- Flamme stabilisée
- Grilles et chapeaux de brûleurs émaillés
- Cadre Inox
- Allumage Automatique
- Commandes frontales

- *Stopsol Glass 60 CM gas hob*
- *4 gas burners*
- *Stabilized flame*
- *Enamelled Grids and burner caps*
- *Stainless steel frame*
- *Automatic ignition*
- *Front knobs*

F 810L



- Vitro moucheté 70 CM
- 4 Bruleurs à gaz
- Flamme stabilisée
- Grilles et chapeaux de brûleurs émaillés
- Allumage Automatique
- Commandes frontales

- *Spotted Glass 70 CM gas hob*
- *4 gas burners*
- *Stabilized flame*
- *Enamelled Grids and burner caps*
- *Automatic ignition*
- *Front knobs*

F 8109B



- Vitro noir 90 CM
- 5 Bruleurs à gaz, l'un Triple Couronnes
- Flamme stabilisée
- Grilles et chapeaux de brûleurs émaillés
- Allumage Automatique
- Commandes frontales

- *Black Glass 90 CM gas hob*
- *5 gas burners, including one Triple Crown burner*
- *Stabilized flame*
- *Enamelled Grids and burner caps*
- *Automatic ignition*
- *Front knobs*

F 818B



- Vitro noir 90 CM
- Modèle de coin
- 4 Bruleurs à gaz, l'un Triple Couronnes
- Flamme stabilisée
- Grilles et chapeaux de brûleurs en fonte
- Allumage Automatique
- Commandes frontales

- *Black Glass 90 CM gas hob*
- *Corner Model*
- *4 gas burners, including one Triple Crown burner*
- *Stabilized flame*
- *Cast Iron Grids and burner caps*
- *Automatic ignition*
- *Front knobs*

Logement d'encastrement  
*Installation drawing*

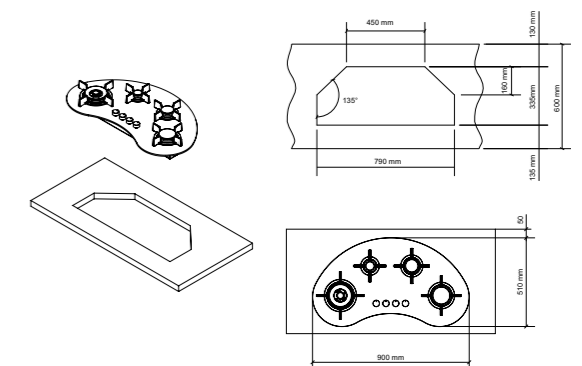
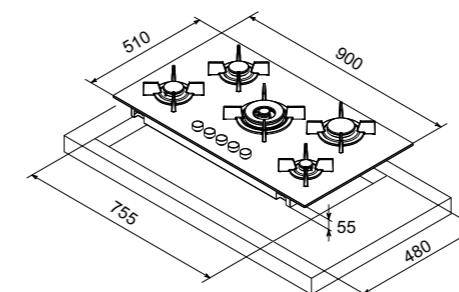
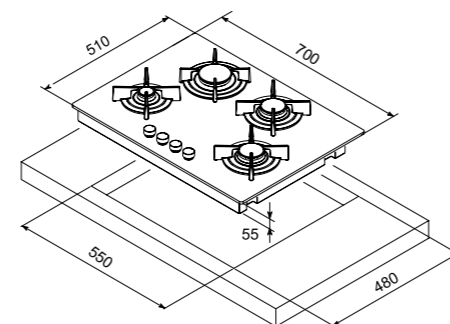
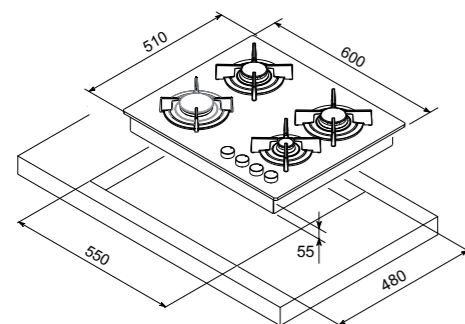

# PLAQUES DE CUISSONS

## HOBS

F 804X



- Inox 60 CM
- 4 Bruleurs à gaz, l'un double Couronnes
- Flamme stabilisée
- Grilles et chapeaux de brûleurs en fonte
- Allumage Automatique
- Commandes frontales

- *Stainless steel 60 CM gas hob*
- *4 gas burners, including one Double Crown burner*
- *Stabilized flame*
- *Cast Iron Grids and burner caps*
- *Automatic ignition*
- *Front knobs*

F 811X



- Inox 75 CM
- 5 Bruleurs à gaz, l'un Triple Couronnes
- Flamme stabilisée
- Grilles et chapeaux de brûleurs en fonte
- Allumage Automatique
- Commandes frontales

- *Stainless steel 75 CM gas hob*
- *5 gas burners, including one Triple Crown burner*
- *Stabilized flame*
- *Cast Iron Grids and burner caps*
- *Automatic ignition*
- *Front knobs*

F 817X



- Inox 90 CM
- 5 Bruleurs à gaz, l'un Triple Couronnes
- Flamme stabilisée
- Grilles et chapeaux de brûleurs en fonte
- Allumage Automatique
- Commandes frontales

- *Stainless steel 90 CM gas hob*
- *5 gas burners, including one Triple Crown burner*
- *Stabilized flame*
- *Cast Iron Grids and burner caps*
- *Automatic ignition*
- *Front knobs*

Logement d'encastrement  
*Installation drawing*

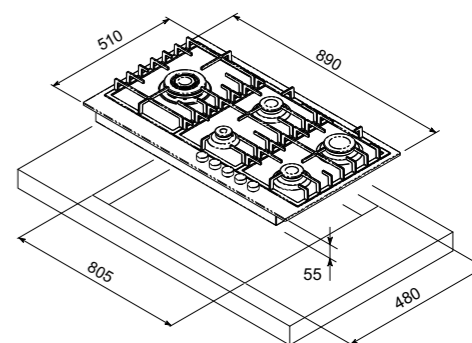
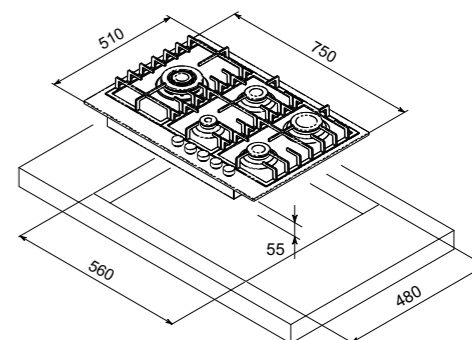
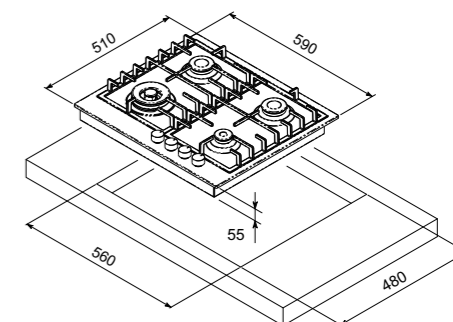

# PLAQUES DE CUISSONS

## HOBS

F 802X



- Inox 60 CM
- 4 Bruleurs à gaz
- Flamme stabilisée
- Grilles et chapeaux de brûleurs en fonte
- Allumage Automatique
- Commandes frontales

- *Stainless steel 60 CM gas hob*
- *4 gas burners*
- *Stabilized flame*
- *Cast Iron Grids and burner caps*
- *Automatic ignition*
- *Front knobs*

F 803X



- Inox 75 CM
- 5 Bruleurs à gaz, l'un Triple Couronnes
- Flamme stabilisée
- Grilles et chapeaux de brûleurs en fonte
- Allumage Automatique
- Commandes frontales

- *Stainless steel 75 CM gas hob*
- *5 gas burners, including one Triple Crown burner*
- *Stabilized flame*
- *Cast Iron Grids and burner caps*
- *Automatic ignition*
- *Front knobs*

F 8039X



- Inox 90 CM
- 5 Bruleurs à gaz, l'un Triple Couronnes
- Flamme stabilisée
- Grilles et chapeaux de brûleurs en fonte
- Allumage Automatique
- Commandes frontales

- *Stainless steel 90 CM gas hob*
- *5 gas burners, including one Triple Crown burner*
- *Stabilized flame*
- *Cast Iron Grids and burner caps*
- *Automatic ignition*
- *Front knobs*

Logement d'encastrement  
*Installation drawing*

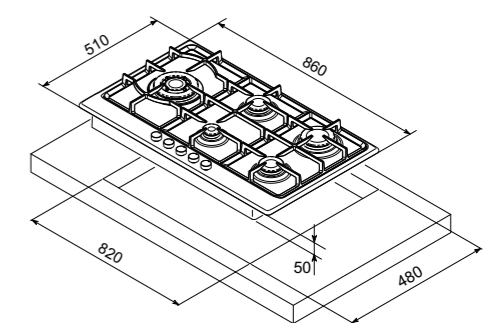
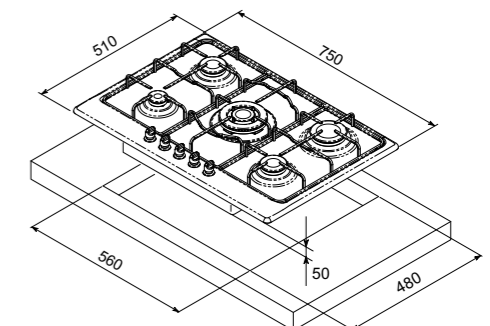
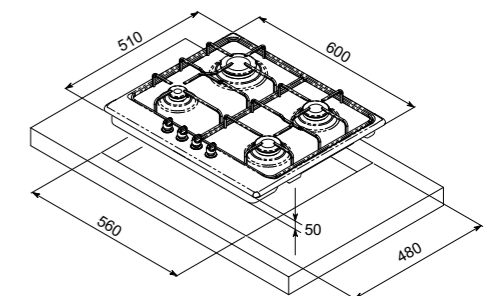



# PLAQUES DE CUISSONS

## HOBS

F 808X



- Inox 60 CM
- 4 Bruleurs à gaz
- Flamme stabilisée
- Grilles et chapeaux de brûleurs en fonte
- Allumage Automatique
- Commandes frontales

- *Stainless steel 60 CM gas hob*
- *4 gas burners*
- *Stabilized flame*
- *Cast Iron Grids and burner caps*
- *Automatic ignition*
- *Front knobs*

F 878X



- Inox 75 CM
- 5 Bruleurs à gaz, l'un Triple Couronnes
- Flamme stabilisée
- Grilles et chapeaux de brûleurs en fonte
- Allumage Automatique
- Commandes frontales

- *Stainless steel 75 CM gas hob*
- *5 gas burners, including one Triple Crown burner*
- *Stabilized flame*
- *Cast Iron Grids and burner caps*
- *Automatic ignition*
- *Front knobs*

F 898X



- Inox 90 CM
- 5 Bruleurs à gaz, l'un Triple Couronnes
- Flamme stabilisée
- Grilles et chapeaux de brûleurs en fonte
- Allumage Automatique
- Commandes frontales

- *Stainless steel 90 CM gas hob*
- *5 gas burners, including one Triple Crown burner*
- *Stabilized flame*
- *Cast Iron Grids and burner caps*
- *Automatic ignition*
- *Front knobs*

Logement d'encastrement  
*Installation drawing*

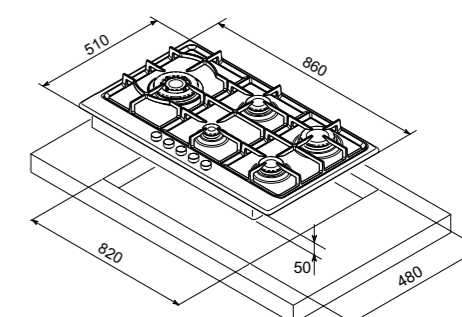
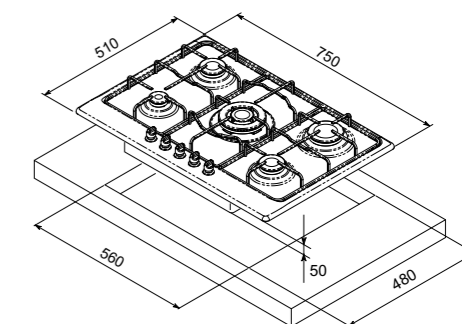
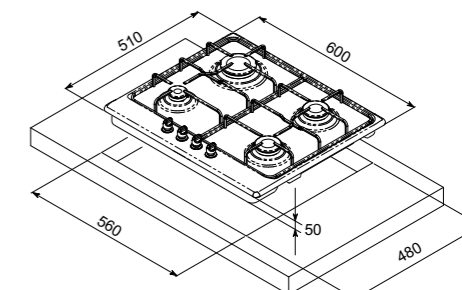

# PLAQUES DE CUISSONS

## HOBS

F 802B



- Noir 60 CM
- 4 Bruleurs à gaz
- Flamme stabilisée
- Grilles et chapeaux de brûleurs en fonte
- Allumage Automatique
- Commandes frontales

- Black 60 CM gas hob
- 4 gas burners
- Stabilized flame
- Cast Iron Grids and burner caps
- Automatic ignition
- Front knobs

F 803B



- Noir 75 CM
- 5 Bruleurs à gaz, l'un Triple Couronnes
- Flamme stabilisée
- Grilles et chapeaux de brûleurs en fonte
- Allumage Automatique
- Commandes frontales

- Black 75 CM gas hob
- 5 gas burners, including one Triple Crown burner
- Stabilized flame
- Cast Iron Grids and burner caps
- Automatic ignition
- Front knobs

F 8039B



- Noir 90 CM
- 5 Bruleurs à gaz, l'un Triple Couronnes
- Flamme stabilisée
- Grilles et chapeaux de brûleurs en fonte
- Allumage Automatique
- Commandes frontales

- Black 90 CM gas hob
- 5 gas burners, including one Triple Crown burner
- Stabilized flame
- Cast Iron Grids and burner caps
- Automatic ignition
- Front knobs

Logement d'encastrement  
Installation drawing

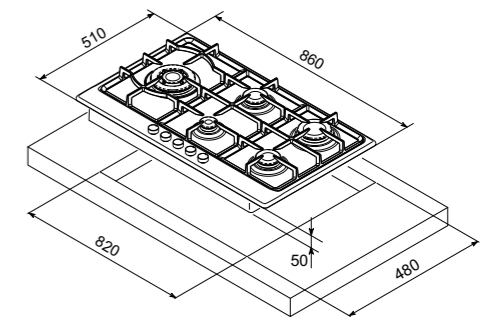
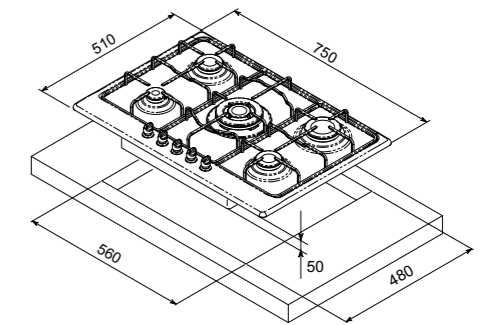
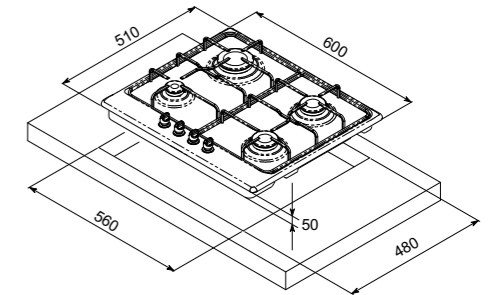

# PLAQUES DE CUISSONS

## HOBS

F 801X

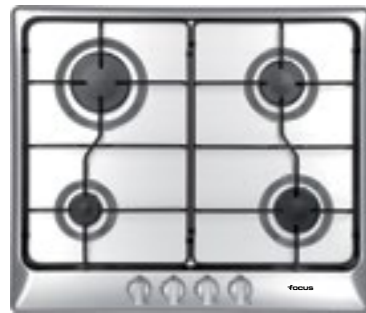

- Inox 60 CM
- 4 Bruleurs à gaz
- Flamme stabilisée
- Grilles et chapeaux de brûleurs émaillés
- Allumage Automatique
- Commandes frontales

- *Stainless steel 60 CM gas hob*
- *4 gas burners*
- *Stabilized flame*
- *Enamelled Grids and burner caps*
- *Automatic ignition*
- *Front knobs*

F 807X

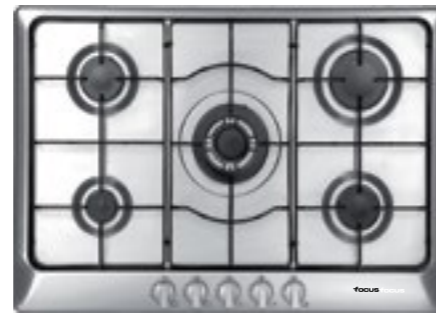

- Inox 75 CM
- 5 Bruleurs à gaz, l'un Triple Couronnes
- Flamme stabilisée
- Grilles et chapeaux de brûleurs émaillés
- Allumage Automatique
- Commandes frontales

- *Stainless steel 75 CM gas hob*
- *5 gas burners, including one Triple Crown burner*
- *Stabilized flame*
- *Enamelled Grids and burner caps*
- *Automatic ignition*
- *Front knobs*

F 8079X



- Inox 90 CM
- 5 Bruleurs à gaz, l'un Triple Couronnes
- Flamme stabilisée
- Grilles et chapeaux de brûleurs émaillés
- Allumage Automatique
- Commandes frontales

- *Stainless steel 90 CM gas hob*
- *5 gas burners, including one Triple Crown burner*
- *Stabilized flame*
- *Enamelled Grids and burner caps*
- *Automatic ignition*
- *Front knobs*

Logement d'encastrement  
*Installation drawing*

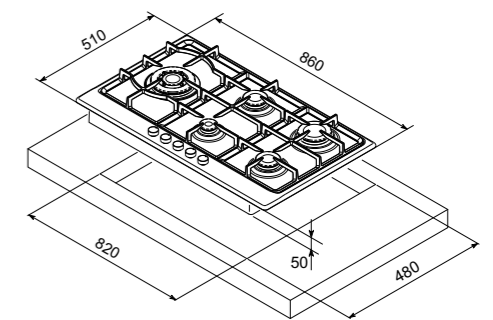
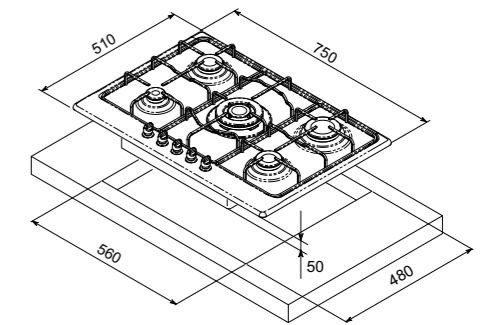
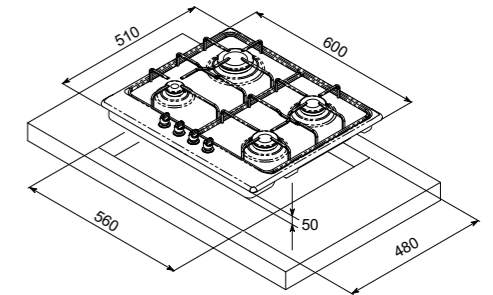

# PLAQUES DE CUISSONS

## HOBS

F 801B



- Noir 60 CM
- 4 Bruleurs à gaz
- Flamme stabilisée
- Grilles et chapeaux de brûleurs émaillés
- Allumage Automatique
- Commandes frontales

- *Black 60 CM gas hob*
- *4 gas burners*
- *Stabilized flame*
- *Enamelled Grids and burner caps*
- *Automatic ignition*
- *Front knobs*

F 805X



- Inox 60 CM
- 4 Bruleurs à gaz
- Flamme stabilisée
- Grilles et chapeaux de brûleurs émaillés
- Allumage électrique
- Commandes latérales

- *Stainless steel 60 CM gas hob*
- *4 gas burners*
- *Stabilized flame*
- *Enamelled Grids and burner caps*
- *Electronic ignition*
- *Side knobs*

F 806X



- Inox 60 CM
- 3 Bruleurs à gaz
- 1 foyer électrique
- Flamme stabilisée
- Grilles et chapeaux de brûleurs émaillés
- Allumage électrique
- Commandes latérales

- *Stainless steel 60 CM hob*
- *3 gas burners*
- *1 electric Fireplace*
- *Stabilized flame*
- *Enamelled Grids and burner caps*
- *Electronic ignition*
- *Side knobs*

Logement d'encastrement  
*Installation drawing*

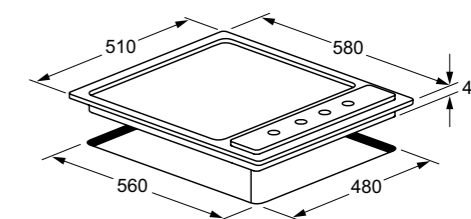
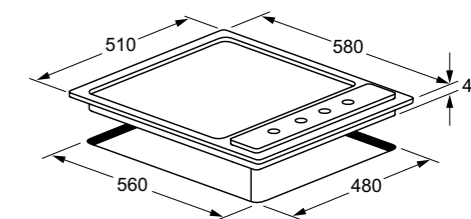
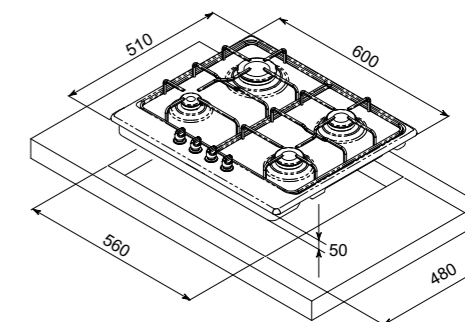

# PLAQUES DE CUISSONS

## HOBS

F 805W

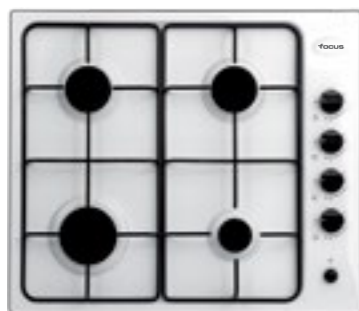

- Blanc 60 CM
- 4 Bruleurs à gaz
- Flamme stabilisée
- Grilles et chapeaux de brûleurs émaillés
- Allumage électrique
- Commandes latérales

- White 60 CM gas hob
- 4 gas burners
- Stabilized flame
- Enamelled Grids and burner caps
- Electronic ignition
- Side knobs

F 801W



- Blanc 60 CM
- 4 Bruleurs à gaz
- Flamme stabilisée
- Grilles et chapeaux de brûleurs émaillés
- Allumage Automatique
- Commandes frontales

- White 60 CM gas hob
- 4 gas burners
- Stabilized flame
- Enamelled Grids and burner caps
- Automatic ignition
- Front knobs

F 807W

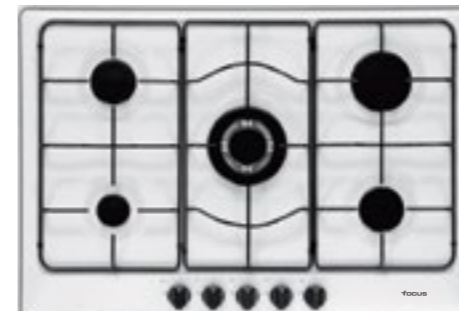

- Blanc 75 CM
- 5 Bruleurs à gaz, l'un Triple Couronnes
- Flamme stabilisée
- Grilles et chapeaux de brûleurs émaillés
- Allumage Automatique
- Commandes frontales

- White 75 CM gas hob
- 5 gas burners, including one Triple Crown burner
- Stabilized flame
- Enamelled Grids and burner caps
- Automatic ignition
- Front knobs

Logement d'encastrement  
Installation drawing

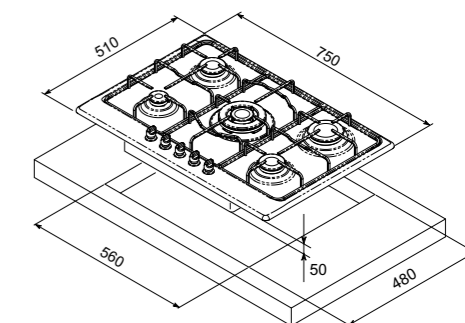
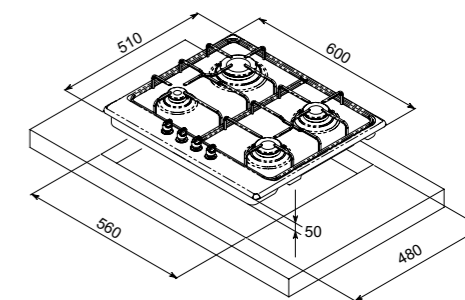
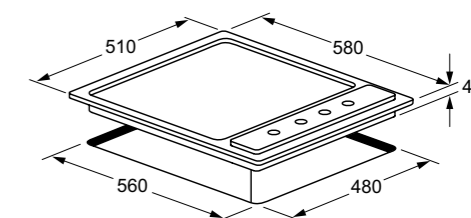

# PLAQUES DE CUISSONS

## HOBS

F 814X



- Inox 60 CM
- 4 foyer électriques
- Commandes latérales

- *Stainless steel 60 CM electric hob*
- *4 electric Fireplaces*
- *Side knobs*

F 812X



- Inox 30 CM
- 2 foyer électriques
- Commandes frontales

- *Stainless steel 30 CM electric hob*
- *2 electric Fireplaces*
- *Front knobs*

F 813X



- Inox 30 CM
- 2 Brûleurs à gaz
- Flamme stabilisée
- Grilles et chapeaux de brûleurs émaillés
- Allumage Automatique
- Commandes frontales

- *Stainless steel 30 CM gas hob*
- *2 gas burners*
- *Stabilized flame*
- *Enamelled Grids and burner caps*
- *Automatic ignition*
- *Front knobs*

Logement d'encastrement  
*Installation drawing*

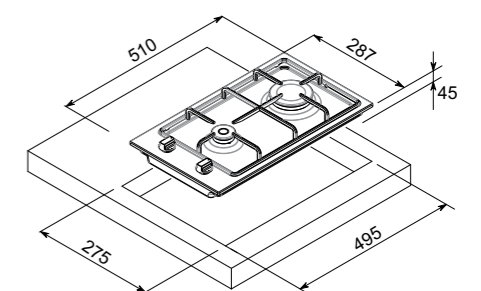
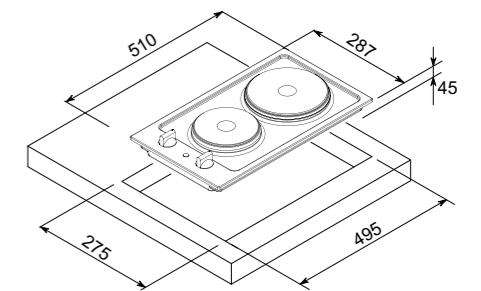
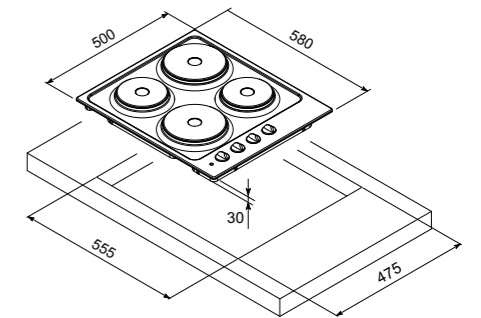

# PLAQUES DE CUISSONS

## HOBS

F 816X



- Vitro céramique 60 CM
- 4 Foyers électriques
- Contrôles sensitifs
- Sécurité enfant
- Indicateurs de chaleur

- Ceramic Hob 60 CM
- 4 Electric Fireplaces
- Contrôles sensitifs
- Child lock
- Residual heat indicators

F 876X



- Vitro céramique 77 CM
- 4 Foyers électriques
- Contrôles sensitifs
- Sécurité enfant
- Indicateurs de chaleur

- Ceramic Hob 77 CM
- 4 Electric Fireplaces
- Contrôles sensitifs
- Child lock
- Residual heat indicators

F 896X



- Vitro céramique 90 CM
- 4 Foyers électriques
- Contrôles sensitifs
- Sécurité enfant
- Indicateurs de chaleur

- Ceramic Hob 90 CM
- 4 Electric Fireplaces
- Contrôles sensitifs
- Child lock
- Residual heat indicators

Logement d'encastrement  
Installation drawing

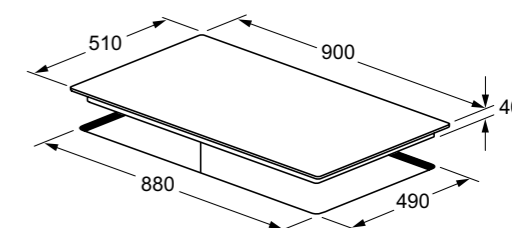
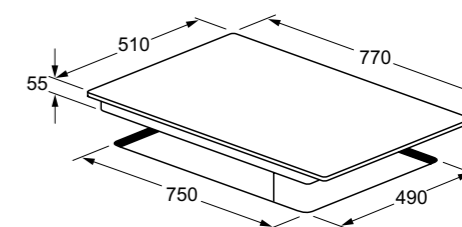
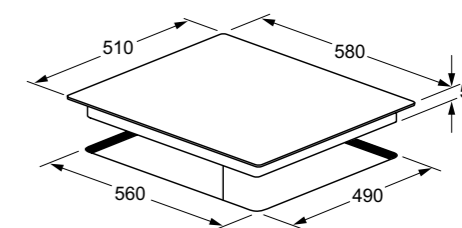

# HÔTTES ASPIRANTES

## HOODS

De nos jours, cuisiner est synonyme d'intuition, de maîtrise, de créativité et d'esthétique.

C'est pourquoi FOCUS a mis au point un ensemble de hottes alliant conception artisanale de grande tradition et de technologies de pointe issues du monde professionnel offrant la précision, la performance, l'efficacité et la sécurité.

Vos recettes les plus sophistiquées deviennent un moment agréable de création et notre nouvelle collection de hottes apportera un souffle d'air frais sur votre créativité culinaire.

*Cooking is synonymous with intuition, mastery, creativity and aesthetics.*

*Therefore FOCUS has developed a set of hoods combines handcrafted design of great tradition and advanced technology from the professional world with precision, performance, efficiency and security.*

*Your most sophisticated recipes become a pleasant moment of creation and our new hoods collection will bring a breath of fresh air to your culinary creativity.*







# HÔTTES ASPIRANTES

## HOODS

ONDA 90



- Hotte Design 90 CM
- Aspiration périmétrale
- Afficheur numérique
- 3 vitesses + 1 turbo
- Touches sensibles
- Débit : 1100 m<sup>3</sup>/h
- Eclairage : 2 Spots LED x 3W
- Filtre aluminium lavable
- Filtre anti-odeur en charbon Optionel
- Classe énergétique A
- Diamètre évacuation : 150 mm

- Design Hood 90 CM
- Perimeter extraction
- Digital display
- 3 Speed + 1 turbo
- Touch Control
- Airflow: 1100 m<sup>3</sup>/h
- Lighting: 2 x 3W LED Spot
- Aluminum filter washable
- Charbon filter Optional
- Energy Class A
- Duct size : 150 mm

FIORA 90



- Hotte Design 90 CM
- Aspiration périmétrale
- Afficheur numérique
- 3 vitesses + 1 turbo
- Touches sensibles
- Débit : 1100 m<sup>3</sup>/h
- Eclairage : 2 Spots LED x 3W
- Filtre aluminium lavable
- Filtre anti-odeur en charbon Optionel
- Classe énergétique A
- Diamètre évacuation : 150 mm

- Design Hood 90 CM Black Glass
- Perimeter extraction
- Digital display
- 3 Speed + 1 turbo
- Touch Control
- Airflow: 1100 m<sup>3</sup>/h
- Lighting: 2 x 3W LED Spot
- Aluminum filter washable
- Charbon filter Optional
- Energy Class A
- Duct size : 150 mm

EUROPA



- Hotte Design 90 CM
- Aspiration périmétrale
- Afficheur numérique
- 3 vitesses + 1 turbo
- Touches sensibles
- Débit : 1100 m<sup>3</sup>/h
- Eclairage : 2 Spots LED x 3W
- Filtre aluminium lavable
- Filtre anti-odeur en charbon Optionel
- Classe énergétique A
- Diamètre évacuation : 150 mm

- Design Hood 90 CM
- Perimeter extraction
- Digital display
- 3 Speed + 1 turbo
- Touch Control
- Airflow: 1100 m<sup>3</sup>/h
- Lighting: 2 x 3W LED Spot
- Aluminum filter washable
- Charbon filter Optional
- Energy Class A
- Duct size : 150 mm

Schéma technique  
Technical drawing

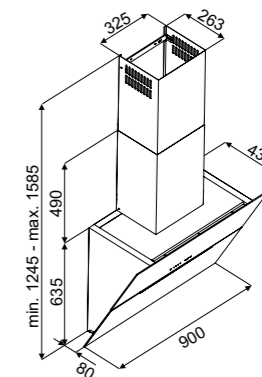
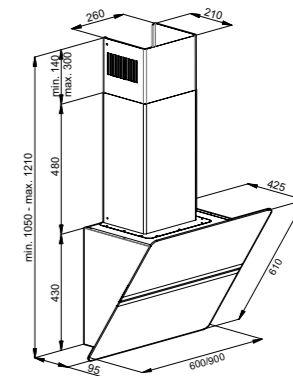
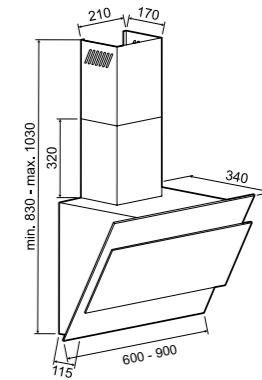

# HÔTTES ASPIRANTES

## HOODS

BARBARA 90



- Hotte Design 90 CM
- Aspiration périmétrale
- Afficheur numérique
- 3 vitesses + 1 turbo
- Touches sensibles
- Débit : 1100 m<sup>3</sup>/h
- Eclairage : bande LED mobile
- Filtre aluminium lavable
- Filtre anti-odeur en charbon Optionel
- Classe énergétique A
- Diamètre évacuation : 150 mm

- *Design Hood 90 CM Black Glass*
- *Perimeter extraction*
- *Digital display*
- *3 Speed + 1 turbo*
- *Touch Control*
- *Airflow: 1100 m<sup>3</sup>/h*
- *Lighting: LED mobile band*
- *Aluminum filter washable*
- *Charbon filter Optional*
- *Energy Class A*
- *Duct size : 150 mm*

SIENA 90



- Hotte Design 90 CM
- Aspiration périmétrale
- Afficheur numérique
- 3 vitesses + 1 turbo
- Touches sensibles
- Débit : 1100 m<sup>3</sup>/h
- Eclairage : 2 Spots LED x 3W
- Filtre aluminium lavable
- Filtre anti-odeur en charbon Optionel
- Classe énergétique A
- Diamètre évacuation : 150 mm

- *Design Hood 90 CM Black Glass*
- *Perimeter extraction*
- *Digital display*
- *3 Speed + 1 turbo*
- *Touch Control*
- *Airflow: 1100 m<sup>3</sup>/h*
- *Lighting: 2 x 3W LED Spot*
- *Aluminum filter washable*
- *Charbon filter Optional*
- *Energy Class A*
- *Duct size : 150 mm*

CURVA 90



- Hotte Design 90 CM
- Aspiration périmétrale
- Afficheur numérique
- 3 vitesses + 1 turbo
- Touches sensibles
- Débit : 1100 m<sup>3</sup>/h
- Eclairage : bande LED
- Filtre aluminium lavable
- Filtre anti-odeur en charbon Optionel
- Classe énergétique A
- Diamètre évacuation : 150 mm

- *Design Hood 90 CM Black Glass*
- *Perimeter extraction*
- *Digital display*
- *3 Speed + 1 turbo*
- *Touch Control*
- *Airflow: 1100 m<sup>3</sup>/h*
- *Lighting: LED band*
- *Aluminum filter washable*
- *Charbon filter Optional*
- *Energy Class A*
- *Duct size : 150 mm*

Schéma technique  
Technical drawing

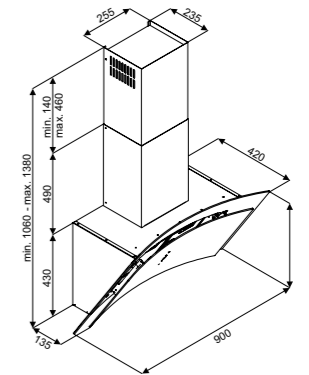
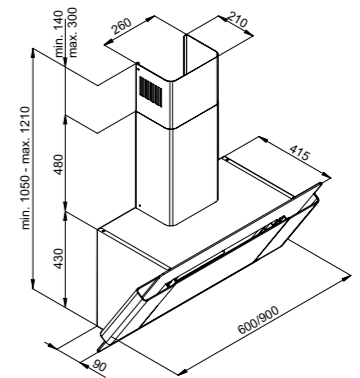
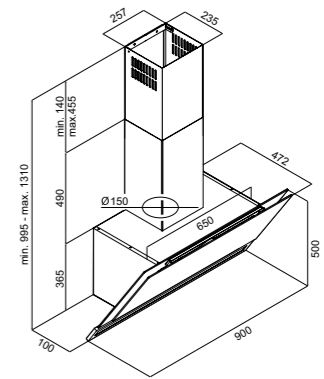

# HÔTTES ASPIRANTES

## HOODS

FABIA W



- Hotte Design 90 CM Blanc
- Aspiration périmétrale
- Afficheur numérique
- 3 vitesses + 1 turbo
- Touches sensibles
- Débit : 1100 m<sup>3</sup>/h
- Eclairage : 2 Spots LED x 3W
- Filtre aluminium lavable
- Filtre anti-odeur en charbon Optionel
- Classe énergétique A
- Diamètre évacuation : 150 mm

- *Design Hood 90 CM White Glass*
- *Perimeter extraction*
- *Digital display*
- *3 Speed + 1 turbo*
- *Touch Control*
- *Airflow: 1100 m<sup>3</sup>/h*
- *Lighting: 2 x 3W LED Spot*
- *Aluminum filter washable*
- *Charbon filter Optional*
- *Energy Class A*
- *Duct size : 150 mm*

FABIA B



- Hotte Design 90 CM Noir
- Aspiration périmétrale
- Afficheur numérique
- 3 vitesses + 1 turbo
- Touches sensibles
- Débit : 1100 m<sup>3</sup>/h
- Eclairage : 2 Spots LED x 3W
- Filtre aluminium lavable
- Filtre anti-odeur en charbon Optionel
- Classe énergétique A
- Diamètre évacuation : 150 mm

- *Design Hood 90 CM Black Glass*
- *Perimeter extraction*
- *Digital display*
- *3 Speed + 1 turbo*
- *Touch Control*
- *Airflow: 1100 m<sup>3</sup>/h*
- *Lighting: 2 x 3W LED Spot*
- *Aluminum filter washable*
- *Charbon filter Optional*
- *Energy Class A*
- *Duct size : 150 mm*

ITALIA



- Hotte Design 90 CM Noir
- Aspiration périmétrale
- Afficheur numérique
- 3 vitesses + 1 turbo
- Touches sensibles
- Débit : 1100 m<sup>3</sup>/h
- Eclairage : 2 Spots LED x 3W
- Filtre aluminium lavable
- Filtre anti-odeur en charbon Optionel
- Classe énergétique A
- Diamètre évacuation : 150 mm

- *Design Hood 90 CM Black Glass*
- *Perimeter extraction*
- *Digital display*
- *3 Speed + 1 turbo*
- *Touch Control*
- *Airflow: 1100 m<sup>3</sup>/h*
- *Lighting: 2 x 3W LED Spot*
- *Aluminum filter washable*
- *Charbon filter Optional*
- *Energy Class A*
- *Duct size : 150 mm*

Schéma technique  
Technical drawing

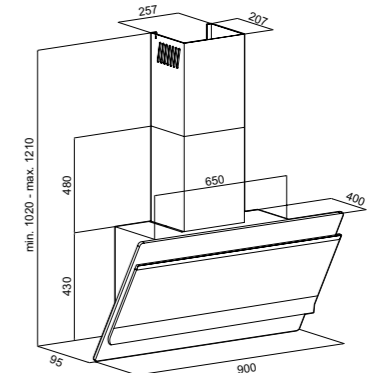
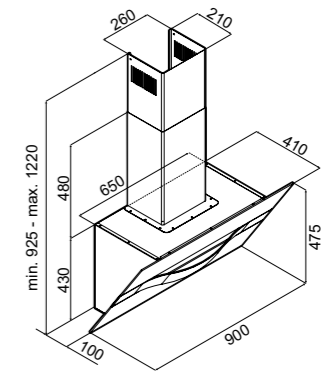
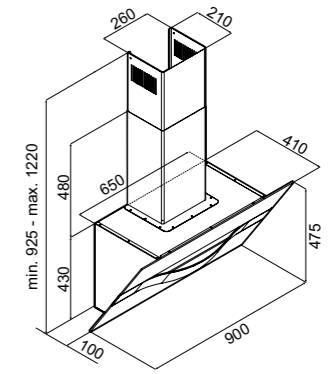

# HÔTTES ASPIRANTES

## HOODS

QUADRA 9010



- Hotte Décorative 90 CM
- Inox + vitro noir
- Afficheur numérique
- 3 vitesses + 1 turbo
- Touches sensibles
- Débit : 1100 m<sup>3</sup>/h
- Eclairage : 2 Spots LED x 3W
- Filtres Inox
- Filtre anti-odeur en charbon Optionel
- Classe énergétique A
- Diamètre évacuation : 150 mm

- Decorative hood 90 CM
- Stainless steel + Black Glass
- Digital display
- 3-speed + 1 turbo
- Touch Control
- Flow: 1100 m<sup>3</sup>/h
- Lighting: 2 x 3W LED Downlights
- Stainless Steel Filters
- Charbon filter Optional
- Energy Class A
- Duct size : 150 mm

FILO 9030



- Hotte Décorative 90 CM
- Inox + vitro noir
- Afficheur numérique
- 3 vitesses + 1 turbo
- Touches sensibles
- Débit : 1100 m<sup>3</sup>/h
- Eclairage : 2 Spots LED x 3W
- Filtres Inox
- Filtre anti-odeur en charbon Optionel
- Classe énergétique A
- Diamètre évacuation : 150 mm

- Decorative hood 90 CM
- Stainless steel + Black Glass
- Digital display
- 3-speed + 1 turbo
- Touch Control
- Flow: 1100 m<sup>3</sup>/h
- Lighting: 2 x 3W LED Downlights
- Stainless Steel Filters
- Charbon filter Optional
- Energy Class A
- Duct size : 150 mm

SOFT 9050



- Hotte Décorative 90 CM
- Inox + vitro noir
- Afficheur numérique
- 3 vitesses + 1 turbo
- Touches sensibles
- Débit : 1100 m<sup>3</sup>/h
- Eclairage : 2 Spots LED x 3W
- Filtres Inox
- Filtre anti-odeur en charbon Optionel
- Classe énergétique A
- Diamètre évacuation : 150 mm

- Decorative hood 90 CM
- Stainless steel + Black Glass
- Digital display
- 3-speed + 1 turbo
- Touch Control
- Flow: 1100 m<sup>3</sup>/h
- Lighting: 2 x 3W LED Downlights
- Stainless Steel Filters
- Charbon filter Optional
- Energy Class A
- Duct size : 150 mm

Schéma technique  
Technical drawing

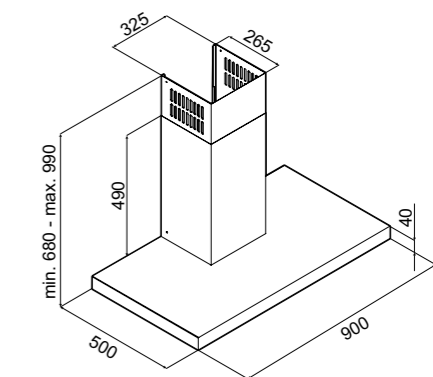
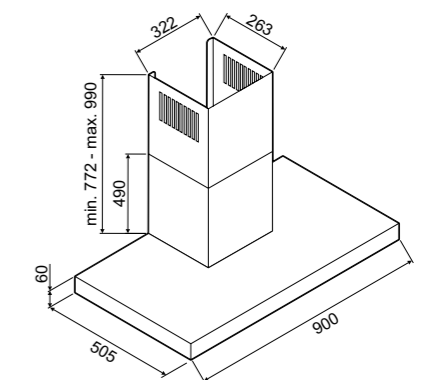
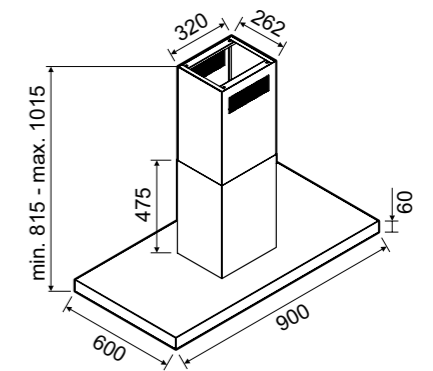

# HÔTTES ASPIRANTES

## HOODS

### SMART 9090



- Hotte Décorative 90 CM
- Modèle Demi-Rond
- Inox + vitro
- Afficheur numérique
- 3 vitesses + 1 turbo
- Touches sensibles
- Débit : 1100 m<sup>3</sup>/h
- Eclairage : 3 Spots Halogène x 20W
- Filtres Inox
- Filtre anti-odeur en charbon Optionel
- Classe énergétique A
- Diamètre évacuation : 150 mm

- Decorative hood 90 CM
- Half-Round model
- Stainless steel + Glass
- Digital display
- 3-speed +1 turbo
- Soft Touch
- Flow: 1100 m<sup>3</sup>/h
- Lighting: 3 x 20W Halogen Downlights
- Stainless Steel Filters
- Charbon filter Optional
- Energy Class A
- Duct size : 150 mm

### SMART 9070



- Hotte Décorative 90 CM
- Inox + vitro
- Afficheur numérique
- 3 vitesses + 1 turbo
- Touches sensibles
- Débit : 1100 m<sup>3</sup>/h
- Eclairage : 2 Spots Halogène x 20W
- Filtres Inox
- Filtre anti-odeur en charbon Optionel
- Classe énergétique A
- Diamètre évacuation : 150 mm

- Decorative hood 90 CM
- Stainless steel + Glass
- Digital display
- 3-speed +1 turbo
- Touch Control
- Flow: 1100 m<sup>3</sup>/h
- Lighting: 2 x 20W Halogen Downlights
- Stainless Steel Filters
- Charbon filter Optional
- Energy Class A
- Duct size : 150 mm

### Schéma technique

#### Technical drawing

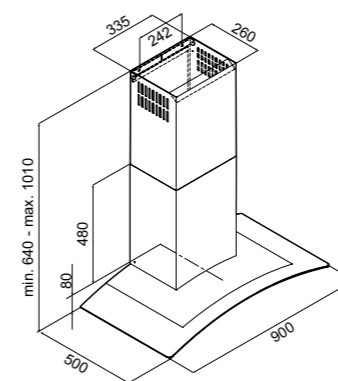
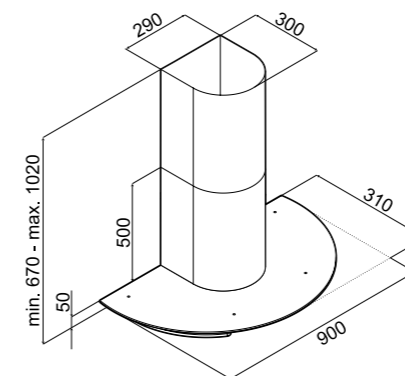

# HÔTTES ASPIRANTES

## HOODS

BARBARA 60



- Hotte Design 60 CM
- Aspiration périmétrale
- Afficheur numérique
- 3 vitesses + 1 turbo
- Touches sensibles
- Débit : 1100 m<sup>3</sup>/h
- Eclairage : bande LED mobile
- Filtre aluminium lavable
- Filtre anti-odeur en charbon Optionel
- Classe énergétique A
- Diamètre évacuation : 150 mm

- Design Hood 60 CM
- Perimeter extraction
- Digital display
- 3 Speed + 1 turbo
- Touch Control
- Airflow: 1100 m<sup>3</sup>/h
- Lighting: LED mobile band
- Aluminum filter washable
- Charbon filter Optional
- Energy Class A
- Duct size : 150 mm

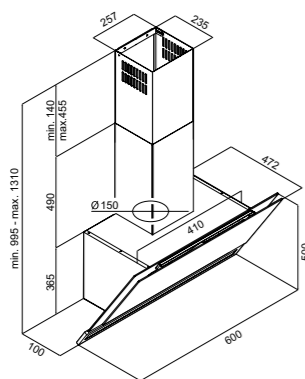

ONDA 60



- Hotte Design 60 CM
- Aspiration périmétrale
- Afficheur numérique
- 3 vitesses + 1 turbo
- Touches sensibles
- Débit : 1100 m<sup>3</sup>/h
- Eclairage : 2 Spots LED x 3W
- Filtre aluminium lavable
- Filtre anti-odeur en charbon Optionel
- Classe énergétique A
- Diamètre évacuation : 150 mm

- Design Hood 60 CM
- Perimeter extraction
- Digital display
- 3 Speed + 1 turbo
- Touch Control
- Airflow: 1100 m<sup>3</sup>/h
- Lighting: 2 x 3W LED Spot
- Aluminum filter washable
- Charbon filter Optional
- Energy Class A
- Duct size : 150 mm

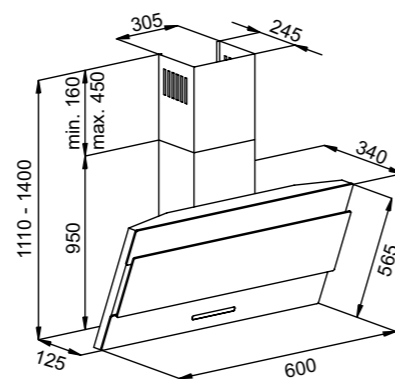

SOFT 6050



- Hotte Décorative 60 CM
- Inox + vitro noir
- Afficheur numérique
- 3 vitesses + 1 turbo
- Touches sensibles
- Débit : 1100 m<sup>3</sup>/h
- Eclairage : 2 Spots LED x 3W
- Filtres Inox
- Filtre anti-odeur en charbon Optionel
- Classe énergétique A
- Diamètre évacuation : 150 mm

- Decorative hood 60 CM
- Stainless steel + Black Glass
- Digital display
- 3-speed + 1 turbo
- Touch Control
- Flow: 1100 m<sup>3</sup>/h
- Lighting: 2 x 3W LED Downlights
- Stainless Steel Filters
- Charbon filter Optional
- Energy Class A
- Duct size : 150 mm

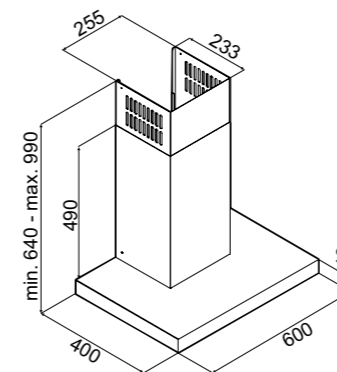

QUADRA 6010



- Hotte Décorative 60 CM
- Inox + vitro noir
- Afficheur numérique
- 3 vitesses + 1 turbo
- Touches sensibles
- Débit : 1100 m<sup>3</sup>/h
- Eclairage : 2 Spots LED x 3W
- Filtres Inox
- Filtre anti-odeur en charbon Optionel
- Classe énergétique A
- Diamètre évacuation : 150 mm

- Decorative hood 60 CM
- Stainless steel + Black Glass
- Digital display
- 3-speed + 1 turbo
- Touch Control
- Flow: 1100 m<sup>3</sup> / h
- Lighting: 2 x 3W LED Downlights
- Stainless Steel Filters
- Charbon filter Optional
- Energy Class A
- Duct size : 150 mm

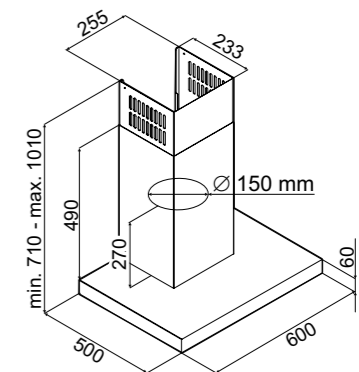

# HÔTTES CENTRALES

## ISLAND HOODS

### QUADRA 9000 / 1120



- Hotte Centrale 90 / 120 CM
- Inox + vitro noir
- Afficheur numérique
- 3 vitesses + 1 turbo
- Touches sensibles
- Débit : 1100 m<sup>3</sup>/h
- Eclairage : 4 Spots LED x 3W
- Filtres Inox
- Filtre anti-odeur en charbon Optionel
- Classe énergétique A
- Diamètre évacuation : 150 mm

- Central hood 90 / 120 CM
- Stainless steel + Black Glass
- Digital display
- 3-speed +1 turbo
- Touch Control
- Flow: 1100 m<sup>3</sup>/h
- Lighting: 4 x 3W LED Downlights
- Stainless Steel Filters
- Charbon filter Optional
- Energy Class A
- Duct size : 150 mm

### SOFT 9040 / 1020



- Hotte Centrale 90 / 120 CM
- Inox + vitro noir
- Afficheur numérique
- 3 vitesses + 1 turbo
- Touches sensibles
- Débit : 1100 m<sup>3</sup>/h
- Eclairage : 4 Spots LED x 3W
- Filtres Inox
- Filtre anti-odeur en charbon Optionel
- Classe énergétique A
- Diamètre évacuation : 150 mm

- Central hood 90 / 120 CM
- Stainless steel + Black Glass
- Digital display
- 3-speed +1 turbo
- Touch Control
- Flow: 1100 m<sup>3</sup>/h
- Lighting: 4 x 3W LED Downlights
- Stainless Steel Filters
- Charbon filter Optional
- Energy Class A
- Duct size : 150 mm

### FILO 9020



- Hotte Centrale 90 CM
- Inox + vitro noir
- Afficheur numérique
- 3 vitesses + 1 turbo
- Touches sensibles
- Débit : 1100 m<sup>3</sup>/h
- Eclairage : 4 Spots LED x 3W
- Filtres Inox
- Filtre anti-odeur en charbon Optionel
- Classe énergétique A
- Diamètre évacuation : 150 mm

- Central hood 90 CM
- Stainless steel + Black Glass
- Digital display
- 3-speed +1 turbo
- Touch Control
- Flow: 1100 m<sup>3</sup>/h
- Lighting: 4 x 3W LED Downlights
- Stainless Steel Filters
- Charbon filter Optional
- Energy Class A
- Duct size : 150 mm

### Schéma technique

#### Technical drawing

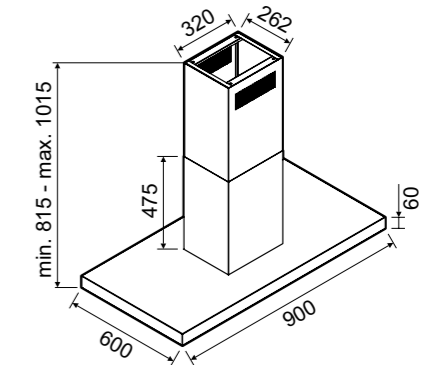
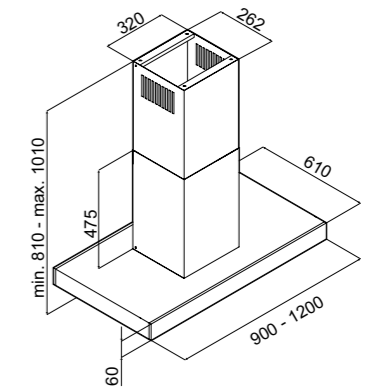
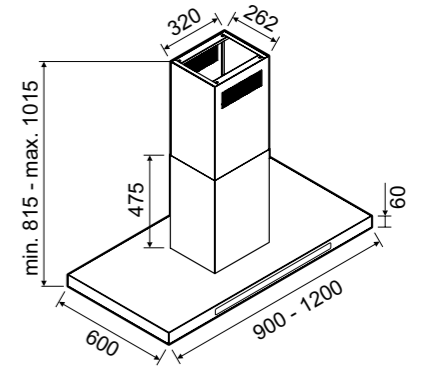



# HÔTTES CENTRALES

## ISLAND HOODS

SMART 9060



- Hotte Centrale 90 CM
- Inox + vitro
- Afficheur numérique
- 3 vitesses + 1 turbo
- Touches sensibles
- Débit : 1100 m<sup>3</sup>/h
- Eclairage : 4 Spots Halogène x 20W
- Filtres Inox
- Filtre anti-odeur en charbon Optionel
- Classe énergétique A
- Diamètre évacuation : 150 mm

- Central hood 90 CM
- Stainless steel + Glass
- Digital display
- 3-speed +1 turbo
- Touch Control
- Flow: 1100 m<sup>3</sup>/h
- Lighting: 4 x 20W Halogen Downlights
- Stainless Steel Filters
- Charbon filter Optional
- Energy Class A
- Duct size : 150 mm

SMART 9080



- Hotte Centrale 90 CM
- Modèle Rond
- Inox + vitro
- Afficheur numérique
- 3 vitesses + 1 turbo
- Touches souples
- Débit : 1100 m<sup>3</sup>/h
- Eclairage : 4 Spots Halogène x 20W
- Filtres Inox
- Filtre anti-odeur en charbon Optionel
- Classe énergétique A
- Diamètre évacuation : 150 mm

- Central hood 90 CM
- Round model
- Stainless steel + Glass
- Digital display
- 3-speed +1 turbo
- Soft keys
- Flow: 1100 m<sup>3</sup>/h
- Lighting: 4 x 20W Halogen Downlights
- Aluminum filter washable
- Charbon filter Optional
- Energy Class A
- Duct size : 150 mm

VASTO



- Hotte Centrale 90 CM
- Modèle Tube
- Aspiration périmétrale
- Inox + vitro noir
- Afficheur numérique
- 3 vitesses + 1 turbo
- Touches sensibles
- Débit : 1100 m<sup>3</sup>/h
- Eclairage : 4 Spots LED x 3W
- Filtre aluminium lavable
- Filtre anti-odeur en charbon Optionel
- Classe énergétique A
- Diamètre évacuation : 150 mm

- Central hood 90 CM
- Tube model
- Perimeter extraction
- Stainless steel + Black Glass
- Digital display
- 3-speed +1 turbo
- Touch Control
- Flow: 1100 m<sup>3</sup>/h
- Lighting: 4 x 3W LED Downlights
- Stainless Steel Filters
- Charbon filter Optional
- Energy Class A
- Duct size : 150 mm

Schéma technique  
Technical drawing

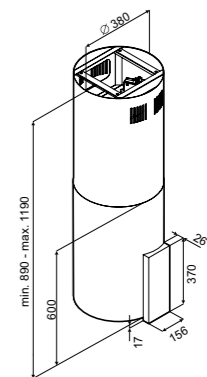
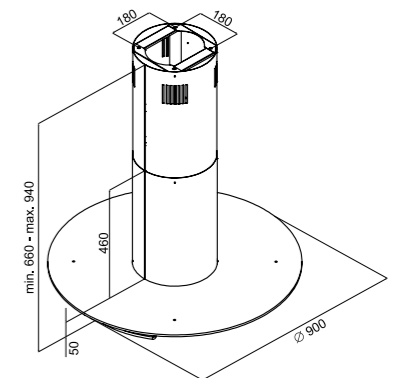
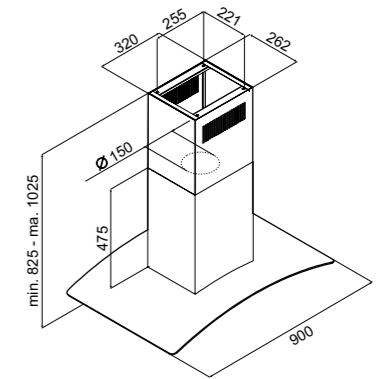

# HÔTTES CENTRALES

## ISLAND HOODS

F 915X



- Hotte Centrale 90 CM
- Inox + vitro
- Afficheur numérique
- 3 vitesses + 1 turbo
- Touches souples
- Débit : 1100 m<sup>3</sup>/h
- Eclairage : 4 Spots Halogène x 20W
- Filtre aluminium lavable
- Filtre anti-odeur en charbon Optionel
- Classe énergétique A
- Diamètre évacuation : 150 mm

- Central hood 90 CM
- Stainless steel + Glass
- Digital display
- 3-speed + 1 turbo
- Soft keys
- Flow: 1100 m<sup>3</sup>/h
- Lighting: 4 x 20W Halogen Downlights
- Aluminum filter washable
- Charbon filter Optional
- Energy Class A
- Duct size : 150 mm

F 917X



- Hotte Centrale 90 CM
- Inox + vitro
- Afficheur numérique
- 3 vitesses + 1 turbo
- Touches souples
- Débit : 1100 m<sup>3</sup>/h
- Eclairage : 4 Spots Halogène x 20W
- Filtre aluminium lavable
- Filtre anti-odeur en charbon Optionel
- Classe énergétique A
- Diamètre évacuation : 150 mm

- Central hood 90 CM
- Stainless steel + Glass
- Digital display
- 3-speed + 1 turbo
- Soft keys
- Flow: 1100 m<sup>3</sup>/h
- Lighting: 4 x 20W Halogen Downlights
- Aluminum filter washable
- Charbon filter Optional
- Energy Class A
- Duct size : 150 mm

F 919X



- Hotte Centrale 90 CM
- Inox
- Afficheur numérique
- 3 vitesses + 1 turbo
- Touches souples
- Débit : 1100 m<sup>3</sup>/h
- Eclairage : 4 Spots Halogène x 20W
- Filtre aluminium lavable
- Filtre anti-odeur en charbon Optionel
- Classe énergétique A
- Diamètre évacuation : 150 mm

- Central hood 90 CM
- Stainless steel
- Digital display
- 3-speed + 1 turbo
- Soft keys
- Flow: 1100 m<sup>3</sup>/h
- Lighting: 4 x 20W Halogen Downlights
- Aluminum filter washable
- Charbon filter Optional
- Energy Class A
- Duct size : 150 mm

Schéma technique  
Technical drawing

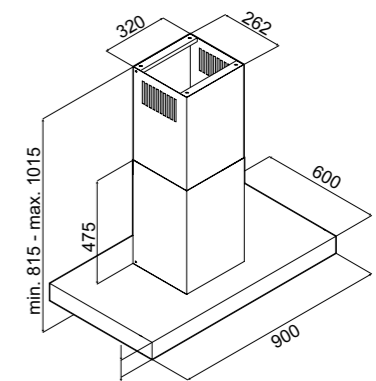
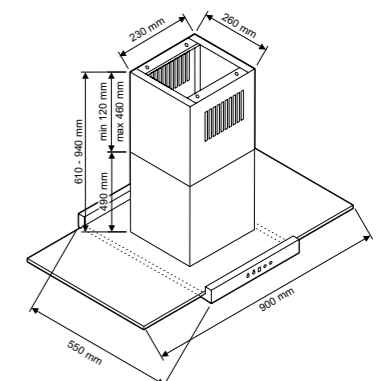
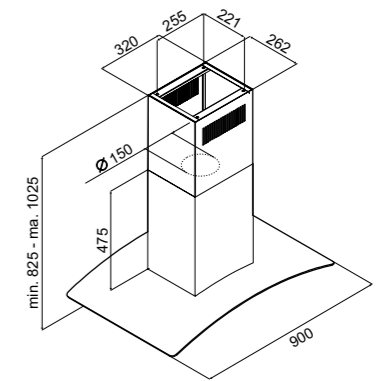

# HÔTTES ASPIRANTES

## HOODS

F 913X



- Hotte Design 90 CM
- Aspiration périmétrale
- Afficheur numérique
- 3 vitesses
- Touches sensibles
- Débit : 600 m<sup>3</sup>/h
- Eclairage : 2 Spots Halogène x 20W
- Filtre aluminium lavable
- Filtre anti-odeur en charbon Optionel
- Classe énergétique A
- Diamètre évacuation : 120 mm

- *Design Hood 90 CM Black Glass*
- *Perimeter extraction*
- *Digital display*
- *3 Speed*
- *Touch Control*
- *Airflow: 600 m<sup>3</sup>/h*
- *Lighting: 2 x 20W Halogen Spot*
- *Aluminum filter washable*
- *Charbon filter Optional*
- *Energy Class A*
- *Duct size : 120 mm*

F 913W



- Hotte Design 90 CM
- Aspiration périmétrale
- Afficheur numérique
- 3 vitesses
- Touches sensibles
- Débit : 600 m<sup>3</sup>/h
- Eclairage : 2 Spots Halogène x 20W
- Filtre aluminium lavable
- Filtre anti-odeur en charbon Optionel
- Classe énergétique A
- Diamètre évacuation : 120 mm

- *Design Hood 90 CM White Glass*
- *Perimeter extraction*
- *Digital display*
- *3 Speed*
- *Touch Control*
- *Airflow: 600 m<sup>3</sup>/h*
- *Lighting: 2 x 20W Halogen Spot*
- *Aluminum filter washable*
- *Charbon filter Optional*
- *Energy Class A*
- *Duct size : 120 mm*

F 1000X



- Hotte de Coin
- Inox 100 CM x 100 CM
- Afficheur numérique
- 5 vitesses + 1 turbo
- Touches souples
- Débit : 1100 m<sup>3</sup>/h
- Eclairage : 3 Spots Halogène x 20W
- Filtre aluminium lavable
- Filtre anti-odeur en charbon Optionel
- Classe énergétique A
- Diamètre évacuation : 125 mm

- *Corner hood*
- *Stainless steel 100 CM x 100 CM*
- *Digital display*
- *5-speed + 1 turbo*
- *Soft keys*
- *Flow: 1100 m<sup>3</sup>/h*
- *Lighting: 3 x 20W Halogen Downlights*
- *Aluminum filter washable*
- *Charbon filter Optional*
- *Energy Class A*
- *Duct size : 125 mm*

Schéma technique  
Technical drawing

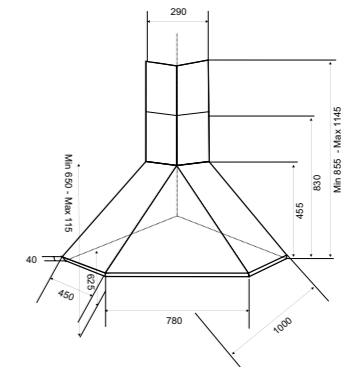
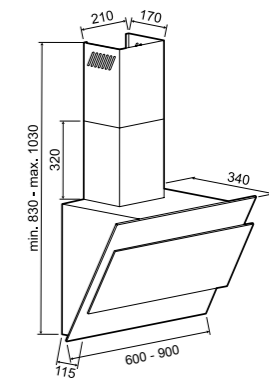
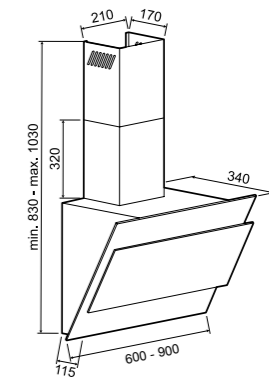

# HÔTTES ASPIRANTES

## HOODS

F 914X



- Hotte Cheminée 90 CM
- Inox + vitro
- Afficheur numérique
- 3 vitesses + 1 turbo
- Touches souples
- Débit : 1100 m<sup>3</sup>/h
- Eclairage : 2 Spots LED x 3W
- Filtres Inox
- Filtre anti-odeur en charbon Optionel
- Classe énergétique A
- Diamètre évacuation : 150 mm

- Cheminy hood 90 CM
- Stainless steel + Glass
- Digital display
- 3-speed +1 turbo
- Soft keys
- Flow: 1100 m<sup>3</sup>/h
- Lighting: 2 x 3W LED Downlights
- Stainless Steel Filters
- Charbon filter Optional
- Energy Class A
- Duct size : 150 mm

F 916X



- Hotte Cheminée 90 CM
- Inox + vitro
- Afficheur numérique
- 3 vitesses + 1 turbo
- Touches souples
- Débit : 1100 m<sup>3</sup>/h
- Eclairage : 2 Spots LED x 3W
- Filtres Inox
- Filtre anti-odeur en charbon Optionel
- Classe énergétique A
- Diamètre évacuation : 150 mm

- Cheminy hood 90 CM
- Stainless steel + Glass
- Digital display
- 3-speed +1 turbo
- Soft keys
- Flow: 1100 m<sup>3</sup>/h
- Lighting: 2 x 3W LED Downlights
- Stainless Steel Filters
- Charbon filter Optional
- Energy Class A
- Duct size : 150 mm

F 918X



- Hotte Cheminée 90 CM
- Inox
- Afficheur numérique
- 3 vitesses + 1 turbo
- Touches souples
- Débit : 1100 m<sup>3</sup>/h
- Eclairage : 2 Spots Halogène x 20W
- Filtre aluminium lavable
- Filtre anti-odeur en charbon Optionel
- Classe énergétique A
- Diamètre évacuation : 150 mm

- Cheminy hood 90 CM
- Stainless steel
- Digital display
- 3-speed +1 turbo
- Soft keys
- Flow: 1100 m<sup>3</sup>/h
- Lighting: 2 x 20W Halogen Downlights
- Aluminum filter washable
- Charbon filter Optional
- Energy Class A
- Duct size : 150 mm

Schéma technique  
Technical drawing

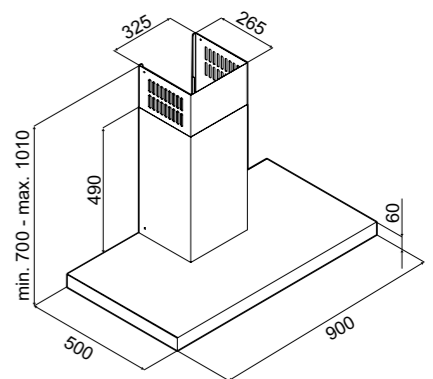
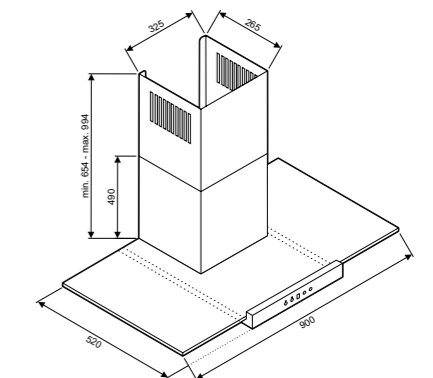
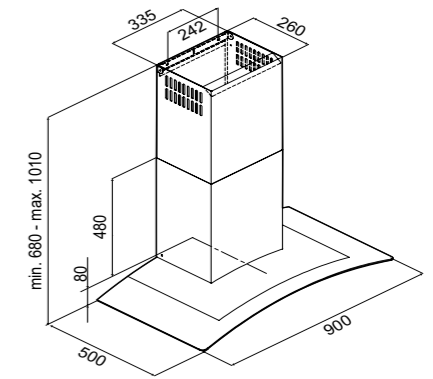

# HÔTTES ASPIRANTES

## HOODS

F 912X



- Hotte Cheminée 90 CM
- Inox
- Afficheur numérique
- 3 vitesses + 1 turbo
- Touches souples
- Débit : 1100 m<sup>3</sup>/h
- Eclairage : 2 Spots Halogène x 20W
- Filtre aluminium lavable
- Filtre anti-odeur en charbon Optionel
- Classe énergétique A
- Diamètre évacuation : 150 mm

- *Chimney hood 90 CM*
- *Stainless steel*
- *Digital display*
- *3-speed + 1 turbo*
- *Soft keys*
- *Flow: 1100 m<sup>3</sup>/h*
- *Lighting: 2 x 20W Halogen Downlights*
- *Aluminum filter washable*
- *Charbon filter Optional*
- *Energy Class A*
- *Duct size : 150 mm*

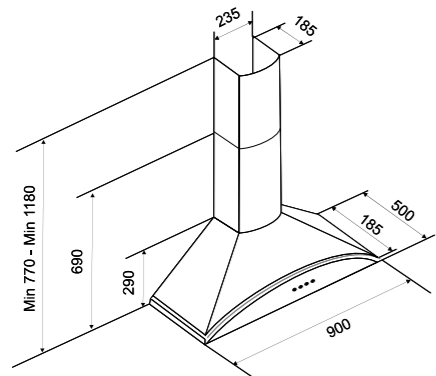

F 906X



- Hotte Cheminée 90 CM
- Modèle Demi-Rond Inox
- 3 vitesses
- Boutons
- Débit : 850 m<sup>3</sup>/h
- Eclairage : 2 lampes x 40W
- Filtre aluminium lavable
- Filtre anti-odeur en charbon Optionel
- Classe énergétique A
- Diamètre évacuation : 125 mm

- *Chimney hood 90 CM*
- *Stainless steel Half-Round model*
- *3-speed*
- *Buttons*
- *Flow: 850 m<sup>3</sup>/h*
- *Lighting: 2 x 40W Lamps*
- *Aluminum filter washable*
- *Charbon filter Optional*
- *Energy Class A*
- *Duct size : 125 mm*

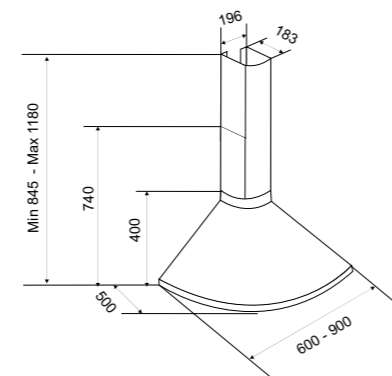

F 904X



- Hotte Cheminée 90 CM
- Modèle Pyramidale Inox
- 3 vitesses
- Boutons
- Débit : 850 m<sup>3</sup>/h
- Eclairage : 2 lampes x 40W
- Filtre aluminium lavable
- Filtre anti-odeur en charbon Optionel
- Classe énergétique A
- Diamètre évacuation : 125 mm

- *Chimney hood 90 CM*
- *Stainless steel Pyramid model*
- *3-speed*
- *Buttons*
- *Flow: 850 m<sup>3</sup>/h*
- *Lighting: 2 x 40W Lamps*
- *Aluminum filter washable*
- *Charbon filter Optional*
- *Energy Class A*
- *Duct size : 125 mm*

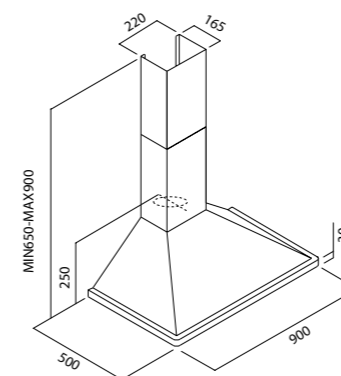

F 905X



- Hotte Cheminée 90 CM
- Modèle Pyramidale Inox
- 3 vitesses
- Boutons
- Débit : 600 m<sup>3</sup>/h
- Eclairage : lampe 28W
- Filtre aluminium lavable
- Filtre anti-odeur en charbon Optionel
- Classe énergétique A
- Diamètre évacuation : 150 mm

- *Chimney hood 90 CM*
- *Stainless steel Pyramid model*
- *3-speed*
- *Buttons*
- *Flow: 600 m<sup>3</sup> / h*
- *Lighting: 28W Lamp*
- *Aluminum filter washable*
- *Charbon filter Optional*
- *Energy Class A*
- *Duct size : 150 mm*

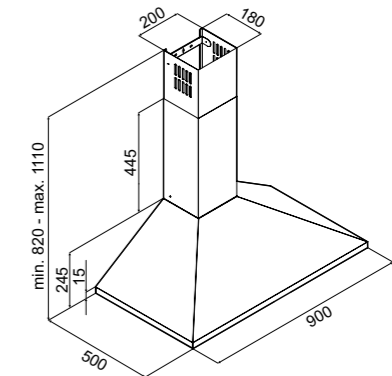

# HÔTTES ASPIRANTES

## HOODS

F 904B



- Hotte Cheminée 90 CM
- Modèle Pyramidale Noir
- 3 vitesses
- Boutons
- Débit : 850 m<sup>3</sup>/h
- Eclairage : 2 lampes x 40W
- Filtre aluminium lavable
- Filtre anti-odeur en charbon Optionel
- Classe énergétique A
- Diamètre évacuation : 125 mm

- Chimney hood 90 CM
- Black Pyramid model
- 3-speed
- Buttons
- Flow: 850 m<sup>3</sup>/h
- Lighting: 2 x 40W Lamps
- Aluminum filter washable
- Charbon filter Optional
- Energy Class A
- Duct size : 125 mm

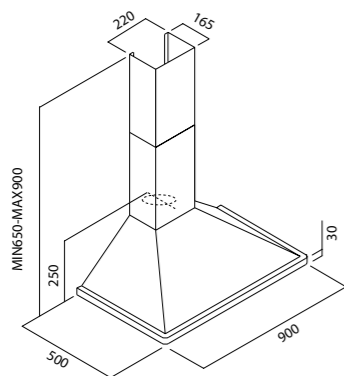

F 905B



- Hotte Cheminée 90 CM
- Modèle Pyramidale Noir
- 3 vitesses
- Boutons
- Débit : 600 m<sup>3</sup>/h
- Eclairage : lampe 28W
- Filtre aluminium lavable
- Filtre anti-odeur en charbon Optionel
- Classe énergétique A
- Diamètre évacuation : 150 mm

- Chimney hood 90 CM
- Black Pyramid model
- 3-speed
- Buttons
- Flow: 600 m<sup>3</sup>/h
- Lighting: 28W Lamp
- Aluminum filter washable
- Charbon filter Optional
- Energy Class A
- Duct size : 150 mm

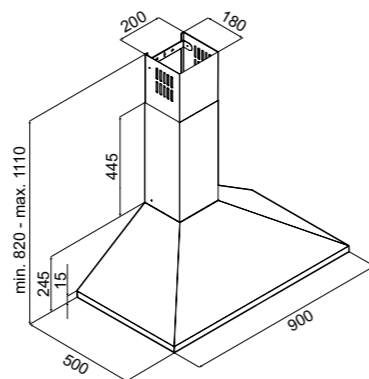

F 905W



- Hotte Cheminée 90 CM
- Modèle Pyramidale Blanc
- 3 vitesses
- Boutons
- Débit : 600 m<sup>3</sup>/h
- Eclairage : lampe 28W
- Filtre aluminium lavable
- Filtre anti-odeur en charbon Optionel
- Classe énergétique A
- Diamètre évacuation : 150 mm

- Chimney hood 90 CM
- White Pyramid model
- 3-speed
- Buttons
- Flow: 600 m<sup>3</sup>/h
- Lighting: 28W Lamp
- Aluminum filter washable
- Charbon filter Optional
- Energy Class A
- Duct size : 150 mm

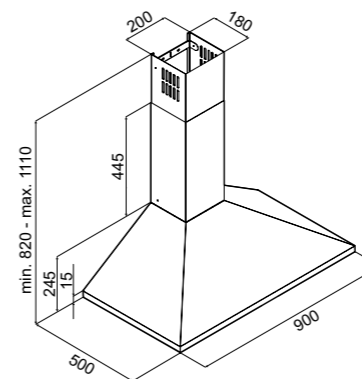

F 902X / W



- Hotte Casquette Inox / Blanc 90 CM
- 3 vitesses
- Boutons
- Débit : 480 m<sup>3</sup>/h
- Eclairage : 2 lampes x 40W
- Filtre aluminium lavable
- Filtre anti-odeur en charbon Optionel
- Classe énergétique A
- Diamètre évacuation : 125 mm

- Built-in Stainless steel / White hood 90 CM
- 3-speed
- Buttons
- Flow: 480 m<sup>3</sup> / h
- Lighting: 2 x 40W Lamps
- Aluminum filter washable
- Charbon filter Optional
- Energy Class A
- Duct size : 125 mm

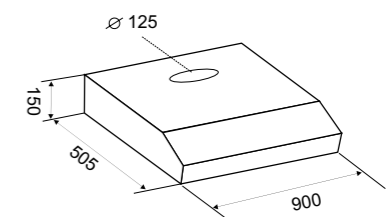

# HÔTTES ASPIRANTES

## HOODS

F 613B



- Hotte Design 60 CM
- Aspiration périmétrale
- Afficheur numérique
- 3 vitesses
- Touches sensibles
- Débit : 600 m<sup>3</sup>/h
- Eclairage : 2 Spots Halogène x 20W
- Filtre aluminium lavable
- Filtre anti-odeur en charbon Optionel
- Classe énergétique A
- Diamètre évacuation : 120 mm

- Design Hood 60 CM
- Perimeter extraction
- Digital display
- 3 Speed
- Touch Control
- Airflow: 600 m<sup>3</sup>/h
- Lighting: 2 x 20W Halogen Spot
- Aluminum filter washable
- Charbon filter Optional
- Energy Class A
- Duct size : 120 mm

F 613W



- Hotte Design 60 CM
- Aspiration périmétrale
- Afficheur numérique
- 3 vitesses
- Touches sensibles
- Débit : 600 m<sup>3</sup>/h
- Eclairage : 2 Spots Halogène x 20W
- Filtre aluminium lavable
- Filtre anti-odeur en charbon Optionel
- Classe énergétique A
- Diamètre évacuation : 120 mm

- Design Hood 60 CM
- Perimeter extraction
- Digital display
- 3 Speed
- Touch Control
- Airflow: 600 m<sup>3</sup>/h
- Lighting: 2 x 20W Halogen Spot
- Aluminum filter washable
- Charbon filter Optional
- Energy Class A
- Duct size : 120 mm

F 610X



- Hotte Cheminée 60 CM
- Inox
- Afficheur numérique
- 3 vitesses + 1 turbo
- Touches souples
- Débit : 1100 m<sup>3</sup>/h
- Eclairage : 2 Spots Halogène x 20W
- Filtre aluminium lavable
- Filtre anti-odeur en charbon Optionel
- Classe énergétique A
- Diamètre évacuation : 150 mm

- Chimney hood 60 CM
- Stainless steel
- Digital display
- 3-speed +1 turbo
- Soft keys
- Flow: 1100 m<sup>3</sup>/h
- Lighting: 2 x 20W Halogen Downlights
- Aluminum filter washable
- Charbon filter Optional
- Energy Class A
- Duct size : 150 mm

Schéma technique  
Technical drawing

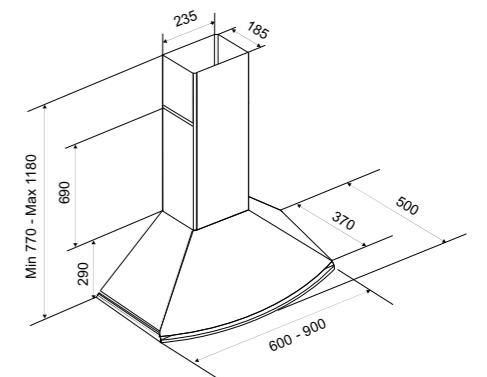
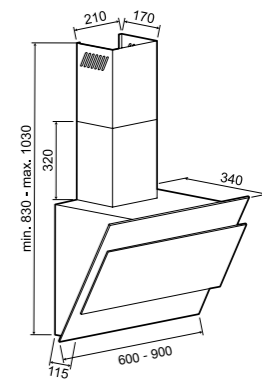
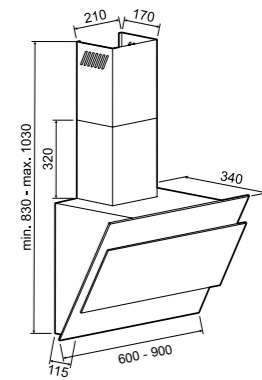

# HÔTTES ASPIRANTES

## HOODS

F 606X



- Hotte Cheminée 60 CM
- Modèle Demi-Rond Inox
- 3 vitesses
- Boutons
- Débit : 600 m<sup>3</sup>/h
- Eclairage : lampe 28W
- Filtre aluminium lavable
- Filtre anti-odeur en charbon Optionel
- Classe énergétique A
- Diamètre évacuation : 150 mm

- Chimney hood 60 CM
- Stainless steel Half-Round model
- 3-speed
- Buttons
- Flow: 600 m<sup>3</sup>/h
- Lighting: 28W Lamp
- Aluminum filter washable
- Charbon filter Optional
- Energy Class A
- Duct size : 150 mm

F 604X



- Hotte Cheminée 60 CM
- Modèle Pyramidale Inox
- 3 vitesses
- Boutons
- Débit : 850 m<sup>3</sup>/h
- Eclairage : 2 lampes x 40W
- Filtre aluminium lavable
- Filtre anti-odeur en charbon Optionel
- Classe énergétique A
- Diamètre évacuation : 125 mm

- Chimney hood 60 CM
- Stainless steel Pyramid model
- 3-speed
- Buttons
- Flow: 850 m<sup>3</sup>/h
- Lighting: 2 x 40W Lamps
- Aluminum filter washable
- Charbon filter Optional
- Energy Class A
- Duct size : 125 mm

F 605X



- Hotte Cheminée 60 CM
- Modèle Pyramidale Inox
- 3 vitesses
- Boutons
- Débit : 600 m<sup>3</sup>/h
- Eclairage : lampe 28W
- Filtre aluminium lavable
- Filtre anti-odeur en charbon Optionel
- Classe énergétique A
- Diamètre évacuation : 150 mm

- Chimney hood 60 CM
- Stainless steel Pyramid model
- 3-speed
- Buttons
- Flow: 600 m<sup>3</sup>/h
- Lighting: 28W Lamp
- Aluminum filter washable
- Charbon filter Optional
- Energy Class A
- Duct size : 150 mm

Schéma technique  
Technical drawing

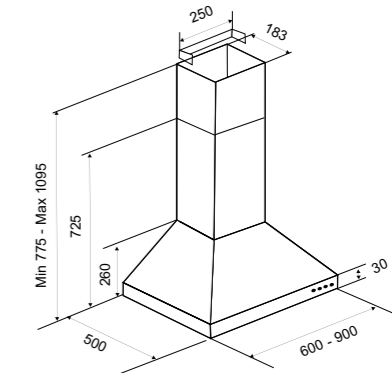
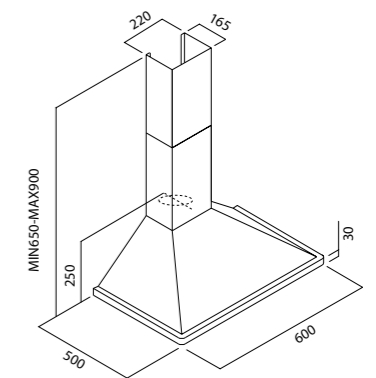
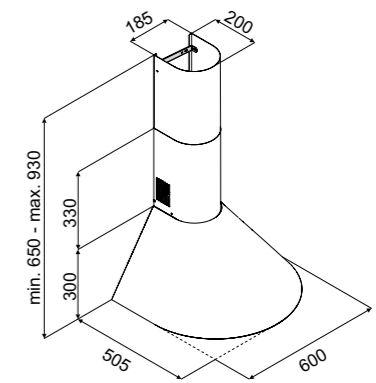



# HÔTTES ASPIRANTES

## HOODS

F 604B



- Hotte Cheminée 60 CM
- Modèle Pyramidale Noir
- 3 vitesses
- Boutons
- Débit : 850 m<sup>3</sup>/h
- Eclairage : 2 lampes x 40W
- Filtre aluminium lavable
- Filtre anti-odeur en charbon Optionel
- Classe énergétique A
- Diamètre évacuation : 150 mm

- *Chimney hood 60 CM*
- *Black Pyramid model*
- *3-speed*
- *Buttons*
- *Flow: 850 m<sup>3</sup>/h*
- *Lighting: 2 x 40W Lamps*
- *Aluminum filter washable*
- *Charbon filter Optional*
- *Energy Class A*
- *Duct size : 150 mm*

F 605B



- Hotte Cheminée 60 CM
- Modèle Pyramidale Noir
- 3 vitesses
- Boutons
- Débit : 600 m<sup>3</sup>/h
- Eclairage : lampe 28W
- Filtre aluminium lavable
- Filtre anti-odeur en charbon Optionel
- Classe énergétique A
- Diamètre évacuation : 150 mm

- *Chimney hood 60 CM*
- *Black Pyramid model*
- *3-speed*
- *Buttons*
- *Flow: 600 m<sup>3</sup>/h*
- *Lighting: 28W Lamp*
- *Aluminum filter washable*
- *Charbon filter Optional*
- *Energy Class A*
- *Duct size : 150 mm*

F 605W



- Hotte Cheminée 60 CM
- Modèle Pyramidale Blanc
- 3 vitesses
- Boutons
- Débit : 600 m<sup>3</sup>/h
- Eclairage : lampe 28W
- Filtre aluminium lavable
- Filtre anti-odeur en charbon Optionel
- Classe énergétique A
- Diamètre évacuation : 150 mm

- *Chimney hood 60 CM*
- *White Pyramid model*
- *3-speed*
- *Buttons*
- *Flow: 600 m<sup>3</sup>/h*
- *Lighting: 28W Lamp*
- *Aluminum filter washable*
- *Charbon filter Optional*
- *Energy Class A*
- *Duct size : 150 mm*

Schéma technique  
Technical drawing

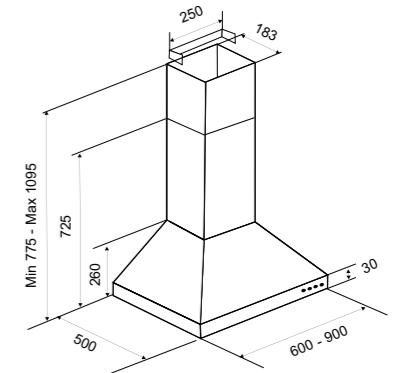
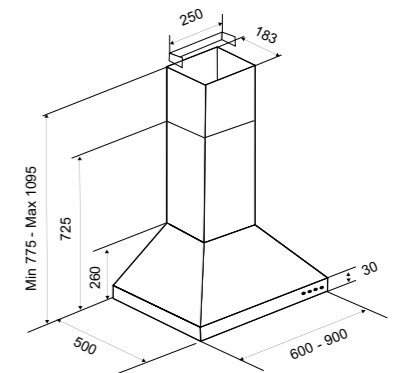
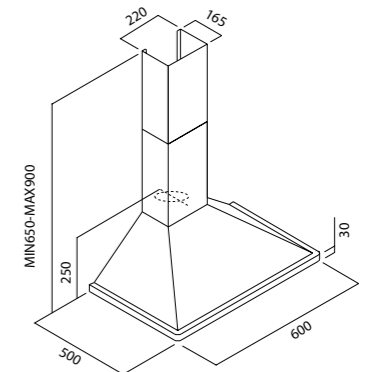

# HÔTTES ASPIRANTES

## HOODS

F 602X / F 602G



- Hotte Casquette Inox / Gris 60 CM
- 3 vitesses
- Boutons
- Débit : 480 m<sup>3</sup>/h
- Eclairage : lampe 28W
- Filtre aluminium lavable
- Filtre anti-odeur en charbon Optionel
- Classe énergétique A
- Diamètre évacuation : 120 mm

- Built-in Stainless steel / Silver hood 60 CM
- 3-speed
- Buttons
- Flow: 480 m<sup>3</sup>/h
- Lighting: 28W Lamp
- Aluminum filter washable
- Charbon filter Optional
- Energy Class A
- Duct size : 120 mm

F 602B / F 602W



- Hotte Casquette Noir / Blanc 60 CM
- 3 vitesses
- Boutons
- Débit : 480 m<sup>3</sup>/h
- Eclairage : lampe 28W
- Filtre aluminium lavable
- Filtre anti-odeur en charbon Optionel
- Classe énergétique A
- Diamètre évacuation : 120 mm

- Built-in Black / White hood 60 CM
- 3-speed
- Buttons
- Flow: 480 m<sup>3</sup>/h
- Lighting: 28W Lamp
- Aluminum filter washable
- Charbon filter Optional
- Energy Class A
- Duct size : 120 mm

F 601X / F 601W



- Hotte Standard Inox / Blanc 60 CM
- 3 vitesses
- Boutons
- Débit : 350 m<sup>3</sup>/h
- Eclairage : 2 lampe x 40W
- Filtre aluminium lavable
- Filtre anti-odeur en charbon Optionel
- Classe énergétique A
- Diamètre évacuation : 125 mm

- Built-in Stainless steel / White hood 60 CM
- 3-speed
- Buttons
- Flow: 350 m<sup>3</sup>/h
- Lighting: 2 x 40W Lamps
- Aluminum filter washable
- Charbon filter Optional
- Energy Class A
- Duct size : 125 mm

Schéma technique  
Technical drawing

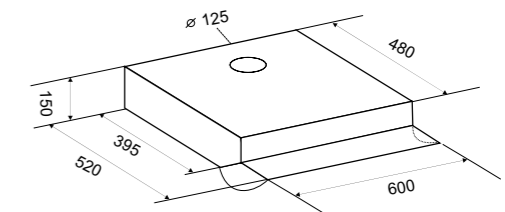
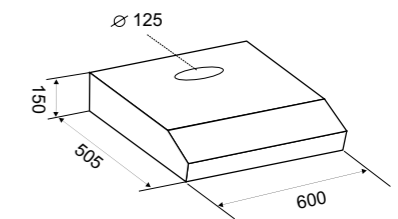
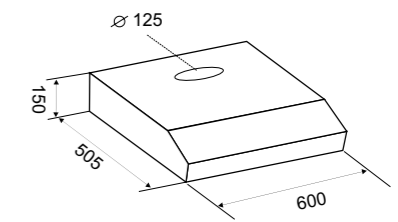

# HÔTTES ASPIRANTES

## HOODS

| RÉFÉRENCE   | TYPE DE FILTRE À CHARBON |         |         |         |        |        |         |         |        |         |
|-------------|--------------------------|---------|---------|---------|--------|--------|---------|---------|--------|---------|
|             | FL 173                   | FWN 160 | FWK 240 | FWK 228 | FL 315 | FL 572 | FWK 280 | FWN 160 | FL 428 | FWK 300 |
| F 601W      | •                        |         |         |         |        |        |         |         |        |         |
| F 601X      | •                        |         |         |         |        |        |         |         |        |         |
| F 602G      |                          | •       |         |         |        |        |         |         |        |         |
| F 602W      |                          | •       |         |         |        |        |         |         |        |         |
| F 602B      |                          | •       |         |         |        |        |         |         |        |         |
| F 602X      |                          | •       |         |         |        |        |         |         |        |         |
| F 605B      |                          |         | ••      |         |        |        |         |         |        |         |
| F 605W      |                          |         | ••      |         |        |        |         |         |        |         |
| F 605X      |                          |         | ••      |         |        |        |         |         |        |         |
| F 606X      |                          |         |         | ••      |        |        |         |         |        |         |
| F 604B      |                          |         |         |         | ••     |        |         |         |        |         |
| F 604X      |                          |         |         |         | ••     |        |         |         |        |         |
| F 610X      |                          |         |         |         | ••     |        |         |         |        |         |
| F 902W      |                          |         |         |         |        | •      |         |         |        |         |
| F 902X      |                          |         |         |         |        |        | •••     |         |        |         |
| F 905B      |                          |         |         |         |        |        | •••     |         |        |         |
| F 905W      |                          |         |         |         |        |        | •••     |         |        |         |
| F 905X      |                          |         |         |         |        |        | •••     |         |        |         |
| F 904B      |                          |         |         |         | ••     |        |         |         |        |         |
| F 904X      |                          |         |         |         | ••     |        |         |         |        |         |
| F 906X      |                          |         |         |         |        |        |         | ••      |        |         |
| F 912X      |                          |         |         |         | ••     |        |         |         |        |         |
| F 914X      |                          |         |         |         |        |        | ••      |         |        |         |
| F 916X      |                          |         |         |         |        |        |         |         |        | •       |
| F 918X      |                          |         |         |         |        |        | •••     |         |        |         |
| F 915X      |                          |         |         |         | ••     |        |         |         |        |         |
| F 917X      |                          |         |         | ••      |        |        |         |         |        | •       |
| F 919X      |                          |         |         |         |        |        | •••     |         |        |         |
| F 1000X     |                          |         |         |         | ••     |        |         |         |        |         |
| F 613B      |                          |         |         | •       |        |        |         |         |        |         |
| F 613W      |                          |         |         | •       |        |        |         |         |        |         |
| ONDA 60     |                          |         | •       |         |        |        |         |         |        |         |
| BABARA 60   |                          |         | •       |         |        |        |         |         |        |         |
| QUADRA 6010 |                          |         | ••      |         |        |        |         |         |        |         |
| SOFT 6050   |                          |         | ••      |         |        |        |         |         |        |         |
| F 913X      |                          |         | ••      |         |        |        |         |         |        |         |
| F 913W      |                          |         | ••      |         |        |        |         |         |        |         |
| FIORA       |                          |         |         | ••      |        |        |         |         |        |         |
| CURVA       |                          |         |         | ••      |        |        |         |         |        |         |
| EUROPA      |                          |         |         |         |        |        | ••      |         |        |         |
| FABIA B     |                          |         |         | ••      |        |        |         |         |        |         |
| FABIA W     |                          |         |         | ••      |        |        |         |         |        |         |
| SIENA       |                          |         |         | ••      |        |        |         |         |        |         |
| ONDA        |                          |         |         | ••      |        |        |         |         |        |         |
| BARBARA     |                          |         |         | ••      |        |        |         |         |        |         |
| ITALIA      |                          |         |         | ••      |        |        |         |         |        |         |
| QUADRA 9010 |                          |         | •••     |         |        |        |         |         |        |         |
| SOFT 9050   |                          |         | •••     |         |        |        |         |         |        |         |
| FLO 9030    |                          |         | •••     |         |        |        |         |         |        |         |
| SMART 9070  |                          |         |         | ••      |        |        |         |         |        |         |
| SMART 9090  |                          |         |         | ••      |        |        |         |         |        |         |
| QUADRA 9000 |                          |         | •••     |         |        |        |         |         |        |         |
| SMART 9060  |                          |         |         | ••      |        |        |         |         |        |         |
| SMART 9080  |                          |         |         |         |        |        | ••      |         |        |         |
| FLO 9020    |                          |         | •••     |         |        |        |         |         |        |         |
| SOFT 9040   |                          |         | •••     |         |        |        |         |         |        |         |
| SOFT 1020   |                          |         |         |         |        |        |         |         |        | •••     |
| QUADRA 1120 |                          |         |         |         |        |        |         |         |        | •••     |
| VASTO       |                          |         |         | •       |        |        |         |         |        |         |

## REFRIGÉRATEURS COOLING

De la pièce de viande au poisson frais proposé par les meilleurs artisans du goût, en passant par de succulents fruits et légumes de saison ou encore les fromages AOC, tous ces aliments coûteux et prestigieux seront conservés dans les meilleures conditions dans un de nos modèles réfrigérateurs.

Vous avez la certitude que tous vos précieux trésors conserveront leur fraîcheur, leur goût originel, ils ne perdront en rien de leur saveur, texture et ils resteront frais plus longtemps.

*Of the meat to fresh fish offered by the best craftsmen of taste, through succulent fruits and vegetables in season or the AOC cheeses, all these expensive and prestigious food will be kept in the best conditions in our cooling models .*

*You are sure that all your precious treasures retain their freshness, their original taste, they lose nothing of their flavor, texture and they will stay fresh longer.*





# REFRIGÉRATEURS

## COOLING

FILO 3200



- Combiné intégrable
- No frost
- Classe énergétique A+
- Volume: 292 litres
- Classe climatique : ST
- Portes Reversibles
- Thermostat réglable
- Clayettes en verre
- Puissance acoustique : 39 dB(A)
- Compartiment congélateur : 3 Tiroirs
- Afficheur électronique

- Built-in refrigerator
- No frost
- Energy efficiency class A +
- Volume : 292 liters
- Climate class : ST
- Reversible doors
- Adjustable thermostat
- Glass Shelves
- 39 dB(A) sound level
- Freezer compartment: 3 Drawers
- Electronic display

FILO 3180



- Combiné intégrable
- Froid Dynamique
- Classe énergétique A+
- Volume: 292 litres
- Classe climatique : ST
- Portes Reversibles
- Thermostat réglable
- Clayettes en verre
- Puissance acoustique : 39 dB(A)
- Compartiment congélateur : 3 Tiroirs

- Built-in refrigerator
- Dynamic Cooling
- Energy efficiency class A +
- Volume : 292 liters
- Climate class : ST
- Reversible doors
- Adjustable thermostat
- Glass Shelves
- 39 dB(A) sound level
- Freezer compartment: 3 Drawers

FILO 3000



- Réfrigérateur intégré
- Froid Dynamique
- Classe énergétique A+
- Volume: 315 Litres
- Dégivrage automatique
- 5 Clayettes en verre réglables
- 5 Bacs de rangement dans la contre-porte
- 2 Bacs à légumes
- Porte réversible

- Built-in fridge
- Dynamic cold
- Energy Class A +
- Total capacity: 315 Litres
- Automatic defrosting
- 5 shelves adjustable glass
- 5 Storage bins against the door
- 2 Crispers
- reversible door

FILO 3100



- Congélateur intégré No Frost
- Tiroirs de congélation transparents
- Classe énergétique A +
- Volume: 220 litres
- Classe climatique: SN-T
- 42 dB (A) Niveau sonore

- Built-in freezer No Frost
- Transparent freezer drawers
- Energy Class A +
- Total capacity: 220 litres
- Climate class: SN-T
- Noise level: 42 dBA

# REFRIGÉRATEURS

## COOLING

Logement d'encastrement  
*Installation drawing*

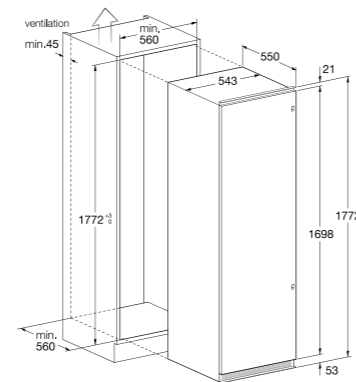
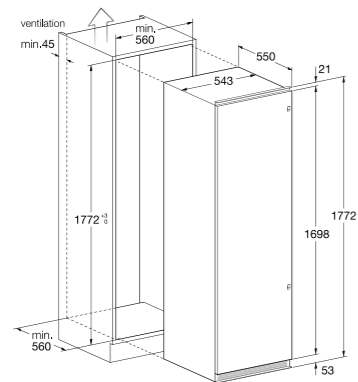
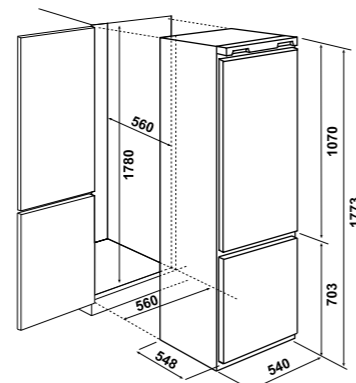
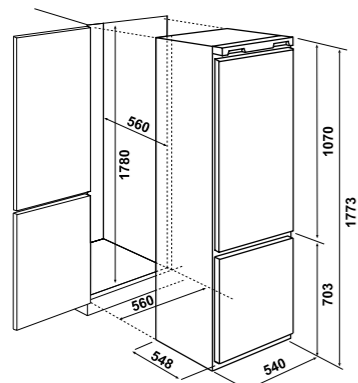

F.585

Logement d'encastrement  
*Installation drawings*

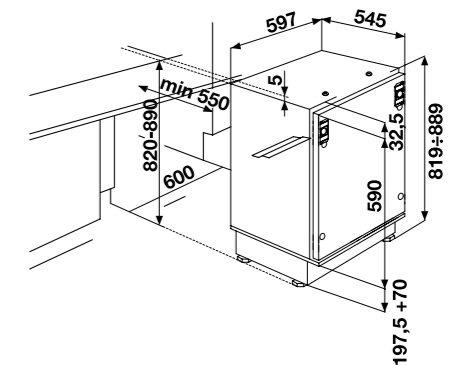

- Réfrigérateur sous plan intégrable
- Classe énergétique : A
- Totalement encastrable
- Volume: 170 litres
- Dégivrag automatique
- Embase ventilé
- Porte Reversible
- Clayettes en verre

- Undercounter built-in refrigerator
- Energy Class: A
- Totally built-in
- Volume: 170L
- Auto Defrost
- Base ventilated
- Reversible Door
- Glass Shelves



# REFRIGÉRATEURS COOLING

SMART 3300 NF



- SIDE BY SIDE No Frost
- Portes en Inox
- Classe énergétique A +
- Volume brut: 632 litres
- Volume net:  
Congélateur: 170 litres  
Réfrigérateur: 434 litres
- Classe climatique: T
- Affichage LED
- Système antibactérien
- Super freeze
- 6 tiroirs de congélation
- Grand Box congélateur
- Bac à glaçons
- Fonction Eco-Vacance au réfrigérateur
- Super cool
- Dégivrage automatique
- 6 étagères réglables en hauteur en verre de sécurité
- Porte du réfrigérateur intérieure avec 5 étagères de porte
- 3 bacs à légumes
- Coquetiers
- Porte-bouteilles
- 39 dB (A) Niveau sonore

SMART 3500 NF / DY



- SIDE BY SIDE
- Portes en Inox
- Congélateur No Frost
- Réfrigérateur Froid Dynamique
- Classe énergétique A +
- Volume: 704 litres
- Classe climatique: T
- Affichage LED
- Système antibactérien
- Super freeze
- 5 tiroirs de congélation
- Grand Box congélateur
- Bac à glaçons
- Fonction Eco-Vacance au réfrigérateur
- Super cool
- Dégivrage automatique
- 6 étagères réglables en hauteur en verre de sécurité
- Porte du réfrigérateur intérieure avec 5 étagères de porte
- 3 bacs à légumes
- Coquetiers
- Porte-bouteilles
- 39 dB (A) Niveau sonore



- SIDE BY SIDE No Frost
- Stainless steel doors
- Freezer No frost
- Fridge Dynamic Cooling
- Energy efficiency class A +
- Gross volume : 632 liters
- Net volume :  
Freezer : 170 liters  
Fridge : 434 liters
- Climate class : T
- LED Display
- Antibacterial System
- Super freeze
- 6 freezer drawers
- Big Box freezer
- Ice Tray
- Fridge Holiday-Eco Function
- Super cool
- Automatic Defrost
- 6 height adjustable shelves in safety glass
- Inner fridge door with 5 door shelves
- 3 vegetable crispers
- Egg cups
- Bottle rack
- 39 dB(A) sound level



- SIDE BY SIDE
- Stainless steel doors
- Freezer No frost
- Fridge Dynamic Cooling
- Energy efficiency class A +
- Volume : 704 liters
- Climate class : T
- LED Display
- Antibacterial System
- Super freeze
- 5 freezer drawers
- Big Box freezer
- Ice Tray
- Fridge Holiday-Eco Function
- Super cool
- Automatic Defrost
- 6 height adjustable shelves in safety glass
- Inner fridge door with 5 door shelves
- 3 vegetable crispers
- Egg cups
- Bottle rack
- 39 dB(A) sound level





## LAVES VAISSELLES DISH WASHERS

Le dîner a été un succès, vos invités ont apprécié dans les moindres détails : de la table parfaitement dressée aux délicieuses recettes, mais voilà, après ce somptueux dîner, il reste à tout nettoyer et retrouver une vaisselle étincelante en toute simplicité. FOCUS a imaginé un nouveau lave-vaisselle qui offre un large choix de programmes et de fonctions adapté à chaque problématique de nettoyage. un design intérieur robuste qui fournit des performances exceptionnelles de lavage et de séchage.

*The dinner was a success, your guests have enjoyed in every detail: the table perfectly erect with delicious recipes, but now, after this sumptuous dinner, it remains to find everything clean and sparkling dishes with ease. FOCUS has devised a new dishwasher that offers a wide range of programs and functions tailored to each Feed harvesting problematic. a robust interior design that provided exceptional performance washing and drying.*



# LAVES VAISSELLES

## DISH WASHERS

### QUADRA 1310



- Semi-encastrable
- Noir avec cadre en inox
- 13 couverts
- 10 programmes
- Classe énergétique : A++
- Ecran LED
- Puissance acoustique : 47 dB(A)
- Dimensions : 82 x 60 x 57
- Pieds réglages
- Faible Consommation : 12 Litres
- Visualisation du déroulement du programme

- *Partially integrated dishwasher*
- *Black with stainless steel frame*
- *13 place settings*
- *10 washing programmes*
- *Energy-efficiency class A++*
- *Digit display*
- *47 dB(A) sound level*
- *Dimension: 82 x 60 x 57*
- *Adjustable feet*
- *Water consumption: 12 Litres*
- *Visualization of program flow*

### SOFT 1310

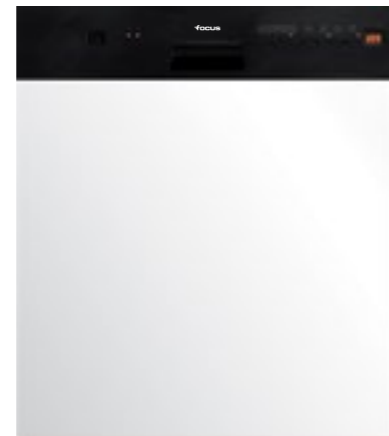

- Semi-encastrable
- Noir
- 13 couverts
- 10 programmes
- Classe énergétique : A++
- Ecran LED
- Puissance acoustique : 47 dB(A)
- Dimensions : 82 x 60 x 57
- Pieds réglages
- Faible Consommation : 12 Litres
- Visualisation du déroulement du programme

- *Partially integrated dishwasher*
- *Black*
- *13 place settings*
- *10 washing programmes*
- *Energy-efficiency class A++*
- *Digit display*
- *47 dB(A) sound level*
- *Dimension: 82 x 60 x 57*
- *Adjustable feet*
- *Water consumption: 12 Litres*
- *Visualization of program flow*

### FILO 1310



- Totalement-encastrable
- Gris
- 13 couverts
- 10 programmes
- Classe énergétique : A++
- Ecran LED
- Puissance acoustique : 47 dB(A)
- Dimensions : 82 x 60 x 57
- Pieds réglages
- Faible Consommation : 12 Litres

- *Fully integrated dishwasher*
- *Silver*
- *13 place settings*
- *10 washing programmes*
- *Energy-efficiency class A++*
- *Digit display*
- *47 dB(A) sound level*
- *Dimension: 82 x 60 x 57*
- *Adjustable feet*
- *Water consumption: 12 Litres*

### Logement d'encastrement

#### Installation drawing

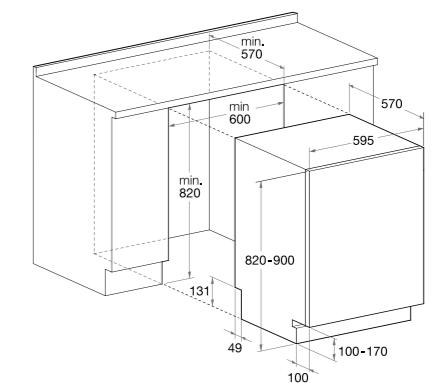
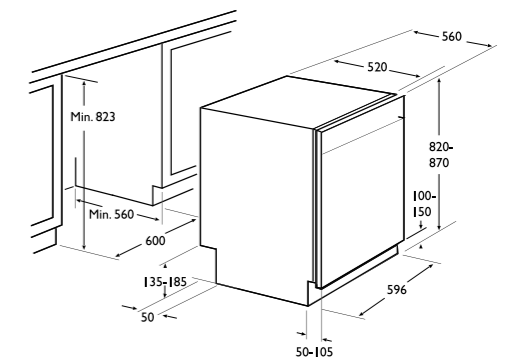
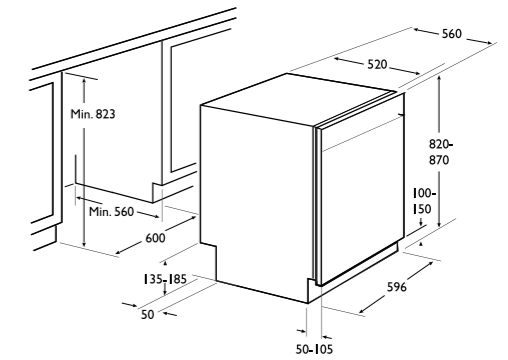

# LAVES VAISSELLES

## DISH WASHERS

F 502X



- Semi-encastrable
- Inox
- 12 couverts
- 6 programmes
- Classe énergétique : A++
- Puissance acoustique : 47 dB(A)
- Dimensions : 82 x 60 x 57
- Pieds réglages
- Faible Consommation : 14 Litres
- Zone de dialogue : visualisation du déroulement du programme

- *Partially integrated dishwasher*
- *Stainless steel*
- *12 place settings*
- *6 washing programmes*
- *Energy-efficiency class A++*
- *47 dB(A) sound level*
- *Dimension: 82 x 60 x 57*
- *Adjustable feet*
- *Water consumption: 14 Litres*
- *Visualization of program flow*

F 501X



- Totalemment encastrable
- Noir
- 12 couverts
- 6 programmes
- Classe énergétique : A++
- Puissance acoustique : 47 dB(A)
- Dimensions : 82 x 60 x 57
- Pieds réglages
- Faible Consommation : 14 Litres
- Visualisation du déroulement du programme

- *Fully integrated dishwasher*
- *Black*
- *12 place settings*
- *6 washing programmes*
- *Energy-efficiency class A++*
- *47 dB(A) sound level*
- *Dimension: 82 x 60 x 57*
- *Adjustable feet*
- *Water consumption: 14 Litres*

Logement d'encastrement  
*Installation drawing*

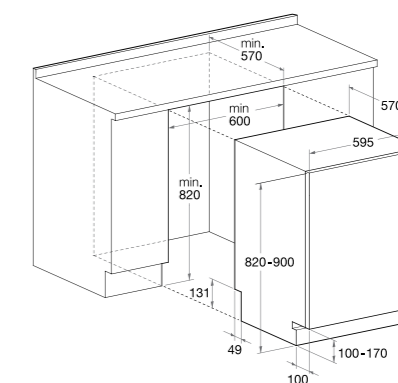
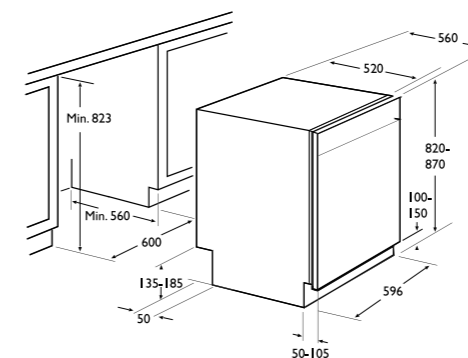





## LAVE LINGES WASHING MACHINES

FILO 1372 / FILO 485



FILO 1372

- Lave-linge tout intégrable
- Capacité de lavage : 7 Kg
- 16 programmes
- Puissance acoustique : 53 dB(A)
- Essorage de 0 à 1000 tr/min
- Départ différé de 1 à 8 heures
- Tambour en inox
- Classe énergétique : A+++

FILO 1372

- Fully integrated washing machine
- Washing capacity: 7 Kg
- 16 programs
- 53 dB(A) sound level
- Spin from 0 to 1000 rev / min
- Start delay from 1 to 8h
- Drum in inox
- Energy-efficiency class A+++

Logement d'encastrement  
*Installation drawing*

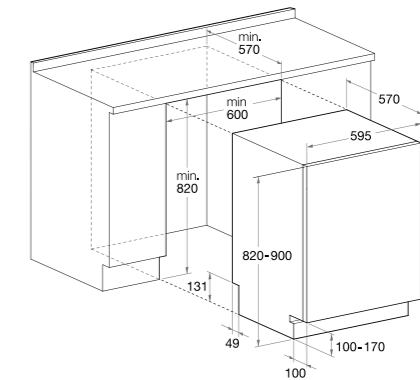

FILO 485

- Lave-linge séchant tout intégrable
- Capacité de lavage : 7 Kg
- Capacité de séchage : 4 Kg
- 16 programmes de lavage
- 1 programme de séchage
- Puissance acoustique : 53 dB(A)
- Essorage de 0 à 1200 tr/min
- Départ différé de 1 à 19 heures
- Tambour en inox
- Classe énergétique : A+

FILO 485

- Fully integrated washer-dryer
- Washing capacity: 7 Kg
- Drying capacity: 4 Kg
- 16 wash programs
- 1 drying program
- 53 dB(A) sound level
- Spin from 0 to 1200 rev / min
- Start delay from 1 to 19h
- Drum in inox
- Energy-efficiency class A+



## ÉVIERS ET MITIGEURS SINKS AND MIXERS

notre mission est révolutionner le concept traditionnel de l'évier de cuisine d'un simple accessoire à un vrai et propre élément d'agencement.

l'évolution des produits FOCUS ne tient pas compte d'un phénomène de mode mais surtout un service qui facilite votre vie.

*our mission is to revolutionize the traditional concept of the kitchen sink with a simple accessory to a true and proper layout element.  
product evolution FOCUS ignores a fad but also a service that makes your life easier.*





# ÉVIERS SINKS

QUADRA 116B



QUADRA 116G



QUADRA 116A



QUADRA 116W



| CODE        | COLOR                   | MESURE     | ENCASTREMENT |
|-------------|-------------------------|------------|--------------|
| QUADRA 116B | Noir<br><i>Black</i>    | 1160 X 515 | 1140 X 480   |
| QUADRA 116G | Gris<br><i>Titanium</i> | 1160 X 515 | 1140 X 480   |
| QUADRA 116A | Grège<br><i>Tortora</i> | 1160 X 515 | 1140 X 480   |
| QUADRA 116W | Blanc<br><i>White</i>   | 1160 X 515 | 1140 X 480   |

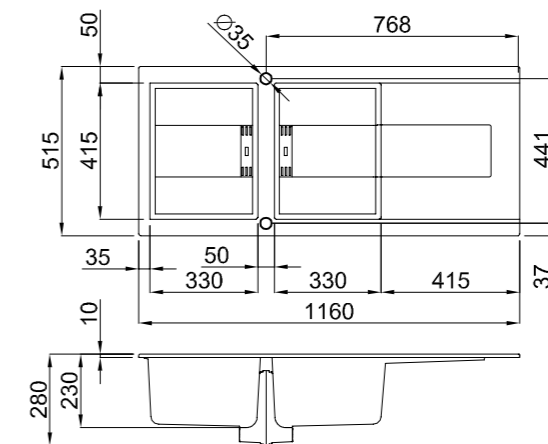
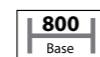

ÉVIERS  
SINKS

QUADRA 86B



QUADRA 86A



QUADRA 86G

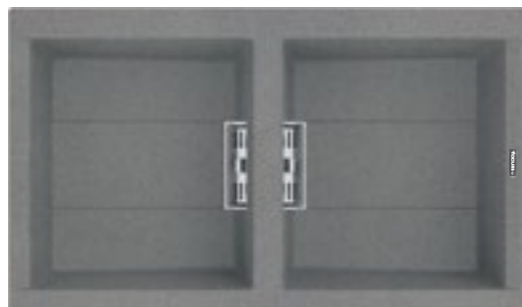

QUADRA 86W



| CODE       | COLOR                   | MESURE    | ENCASTREMENT |
|------------|-------------------------|-----------|--------------|
| QUADRA 86B | Noir<br><i>Black</i>    | 860 X 515 | 840 X 480    |
| QUADRA 86G | Gris<br><i>Titanium</i> | 860 X 515 | 840 X 480    |
| QUADRA 86A | Grège<br><i>Tortora</i> | 860 X 515 | 840 X 480    |
| QUADRA 86W | Blanc<br><i>White</i>   | 860 X 515 | 840 X 480    |

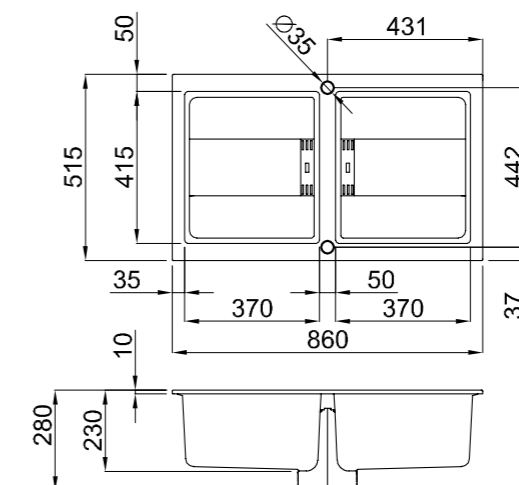
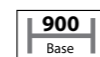

# ÉVIERS SINKS

QUADRA 70B



QUADRA 70A



QUADRA 70G



QUADRA 70W



| CODE       | COLOR                   | MESURE    | ENCASTREMENT |
|------------|-------------------------|-----------|--------------|
| QUADRA 70B | Noir<br><i>Black</i>    | 700 X 500 | 680 X 480    |
| QUADRA 70G | Gris<br><i>Titanium</i> | 700 X 500 | 680 X 480    |
| QUADRA 70A | Grège<br><i>Tortora</i> | 700 X 500 | 680 X 480    |
| QUADRA 70W | Blanc<br><i>White</i>   | 700 X 500 | 680 X 480    |

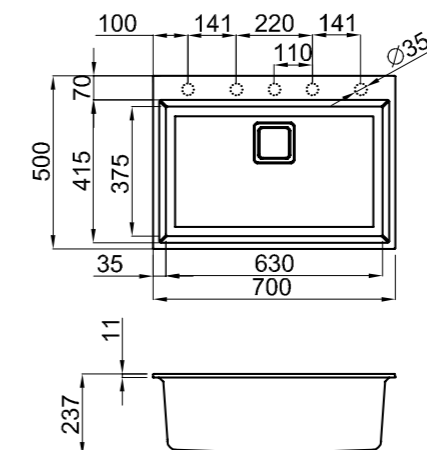
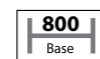

# ÉVIERS SINKS

SOFT 116B



SOFT 116G

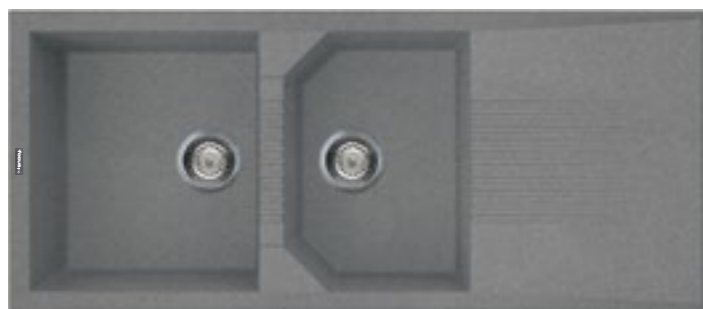

SOFT 116A



SOFT 116W



| CODE      | COLOR                   | MESURE     | ENCASTREMENT |
|-----------|-------------------------|------------|--------------|
| SOFT 116B | Noir<br><i>Black</i>    | 1160 X 500 | 1140 X 480   |
| SOFT 116G | Gris<br><i>Titanium</i> | 1160 X 500 | 1140 X 480   |
| SOFT 116A | Grèce<br><i>Tortora</i> | 1160 X 500 | 1140 X 480   |
| SOFT 116W | Blanc<br><i>White</i>   | 1160 X 500 | 1140 X 480   |

800  
Base

Standard

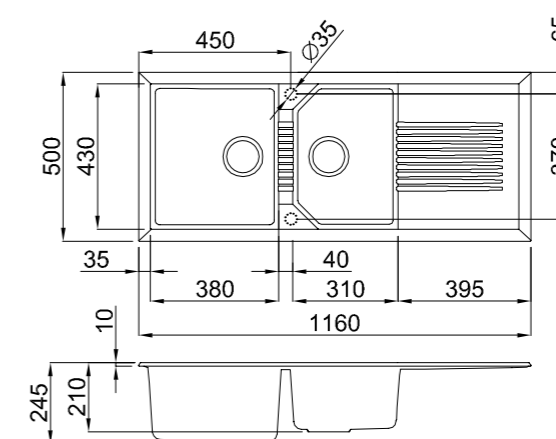

# ÉVIERS SINKS

SOFT 86B



SOFT 86A



SOFT 86G



SOFT 86W



| CODE     | COLOR                   | MESURE    | ENCASTREMENT |
|----------|-------------------------|-----------|--------------|
| SOFT 86B | Noir<br><i>Black</i>    | 860 X 500 | 840 X 480    |
| SOFT 86G | Gris<br><i>Titanium</i> | 860 X 500 | 840 X 480    |
| SOFT 86A | Grège<br><i>Tortora</i> | 860 X 500 | 840 X 480    |
| SOFT 86W | Blanc<br><i>White</i>   | 860 X 500 | 840 X 480    |

500  
Base

Standard

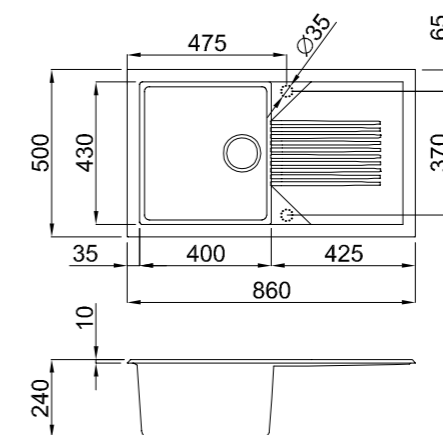

# ÉVIERS SINKS

F 116B



F 116G



F 116A



F 116W



| CODE   | COLOR                   | MESURE     | ENCASTREMENT |
|--------|-------------------------|------------|--------------|
| F 116B | Noir<br><i>Black</i>    | 1160 X 500 | 1140 X 480   |
| F 116G | Gris<br><i>Titanium</i> | 1160 X 500 | 1140 X 480   |
| F 116A | Sable<br><i>Avena</i>   | 1160 X 500 | 1140 X 480   |
| F 116W | Blanc<br><i>White</i>   | 1160 X 500 | 1140 X 480   |

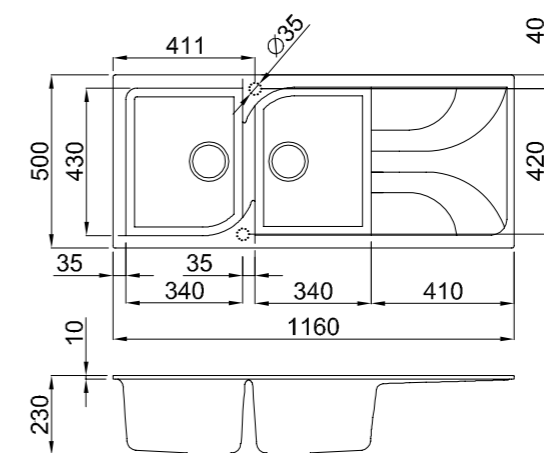
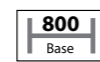

# ÉVIERS SINKS

F 86B



F 86G



F 86A



F 86W



| CODE  | COLOR                   | MESURE    | ENCASTREMENT |
|-------|-------------------------|-----------|--------------|
| F 86B | Noir<br><i>Black</i>    | 860 X 500 | 840 X 485    |
| F 86G | Gris<br><i>Titanium</i> | 860 X 500 | 840 X 485    |
| F 86A | Sable<br><i>Avena</i>   | 860 X 500 | 840 X 485    |
| F 86W | Blanc<br><i>White</i>   | 860 X 500 | 840 X 485    |

450  
Base

Standard

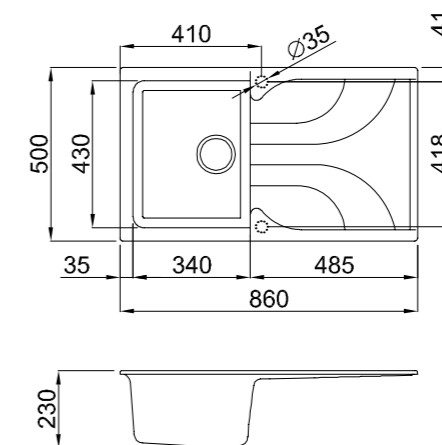

# ÉVIERS SINKS

SMART 38B



SMART 38G



SMART 38A



SMART 38W



| CODE      | COLOR                   | MESURE    | ENCASTREMENT |
|-----------|-------------------------|-----------|--------------|
| SMART 38B | Noir<br><i>Black</i>    | 380 X 440 | 340 X 400    |
| SMART 38G | Gris<br><i>Titanium</i> | 380 X 440 | 340 X 400    |
| SMART 38A | Grège<br><i>Tortora</i> | 380 X 440 | 340 X 400    |
| SMART 38W | Blanc<br><i>White</i>   | 380 X 440 | 340 X 400    |

450  
Base

Sottotop

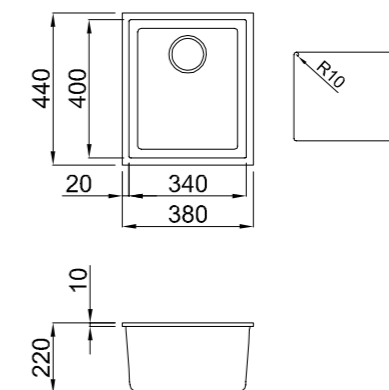



ÉVIERS  
SINKS

SMART 76B



SMART 76A



SMART 76G



SMART 76W



| CODE      | COLOR                   | MESURE    | ENCASTREMENT |
|-----------|-------------------------|-----------|--------------|
| SMART 76B | Noir<br><i>Black</i>    | 760 X 440 | 720 X 400    |
| SMART 76G | Gris<br><i>Titanium</i> | 760 X 440 | 720 X 400    |
| SMART 76A | Grège<br><i>Tortora</i> | 760 X 440 | 720 X 400    |
| SMART 76W | Blanc<br><i>White</i>   | 760 X 440 | 720 X 400    |



Sottotop

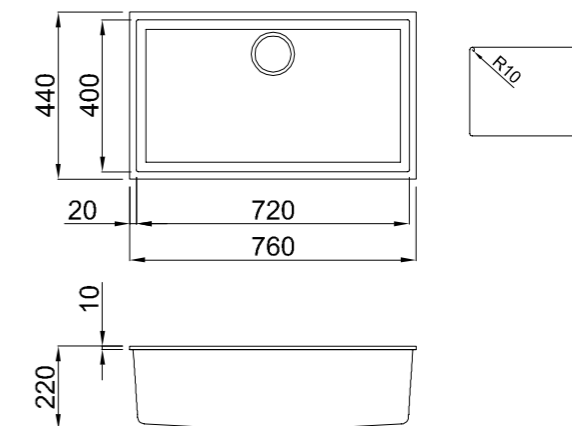

# ÉVIERS SINKS

LNP 1162

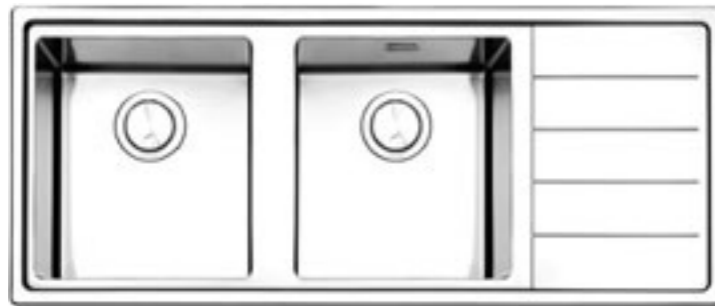

LNP 77



LN 1162



MLE 1162

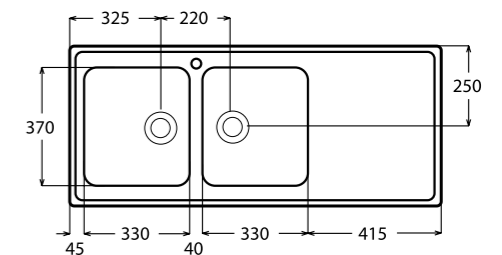
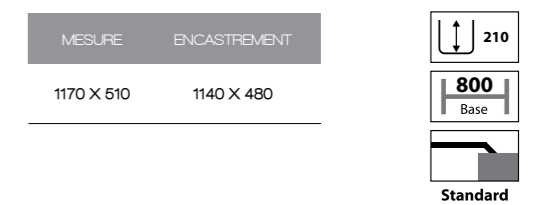
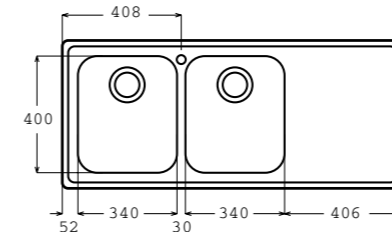
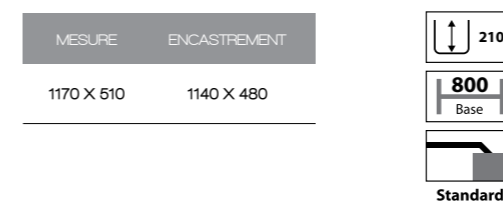
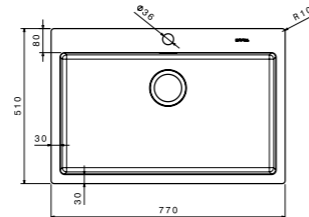
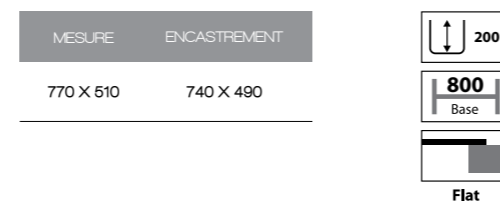
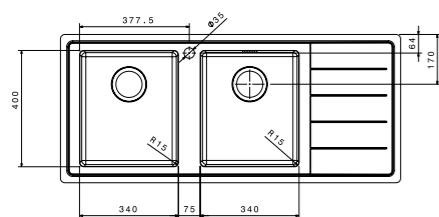
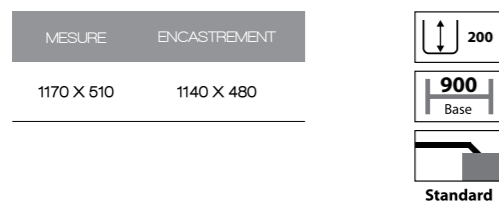

# ÉVIERS SINKS

FH 1162



FH 861



| MESURE     | ENCASTREMENT |
|------------|--------------|
| 1160 X 500 | 1140 X 480   |

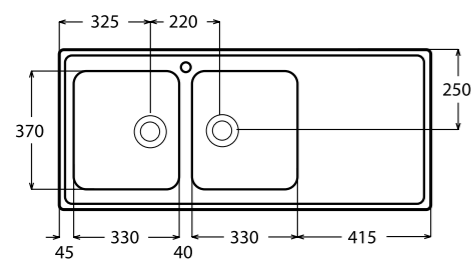
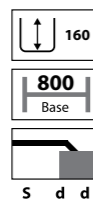

| MESURE    | ENCASTREMENT |
|-----------|--------------|
| 860 X 500 | 840 X 480    |

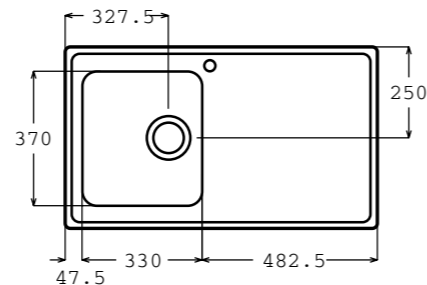



MITIGEURS  
MIXERS

ARES B



ARES G



BLADE B



BLADE CR



ARES W



ARES A



BLADE W



Schéma Technique  
Technical drawing

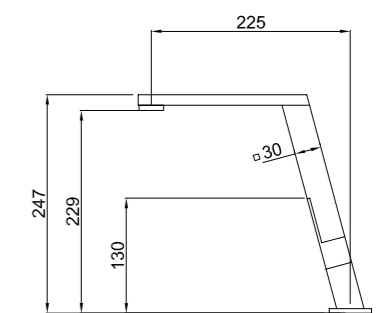

ARES CR



Schéma Technique  
Technical drawing

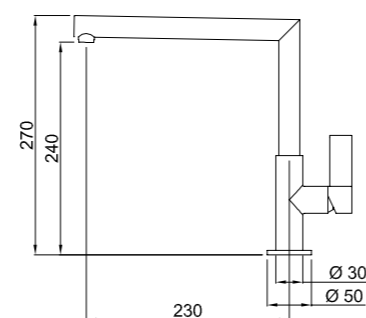

FLY CR B



Schéma Technique  
Technical drawing

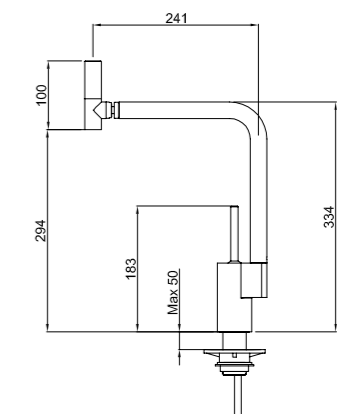

# MITIGEURS

MIXERS

CHEF CR



Schéma Technique  
Technical drawing

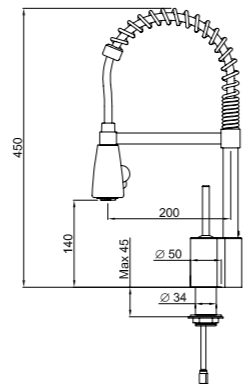

LC 5002 CR



Schéma Technique  
Technical drawing

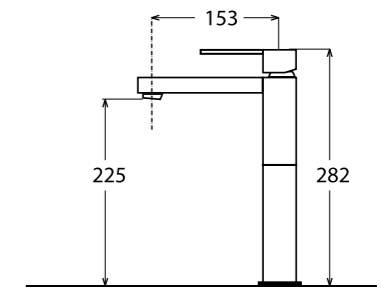

CHEF II CR



Schéma Technique  
Technical drawing

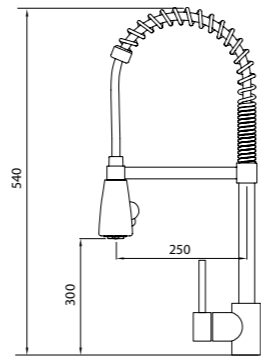

LC 5001 CR



Schéma Technique  
Technical drawing

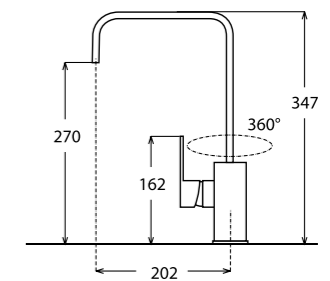

ARNO CR



Schéma Technique  
Technical drawing

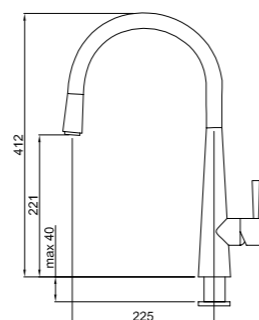

LC 7730 CR



Schéma Technique  
Technical drawing

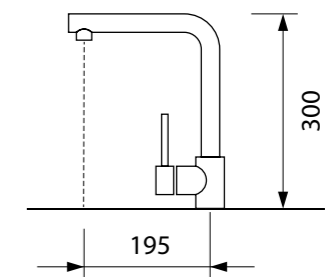

MITIGEURS  
MIXERS

LC 20 B



LC 20 G



LC 4070 CR



LC 4070 G



LC 20 W



LC 20 A



LC 4070 W



LC 4070 A



LC 20 CR



Schéma Technique  
Technical drawing

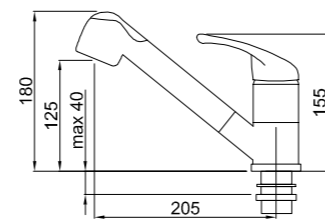

LC 4070 CR



Schéma Technique  
Technical drawing

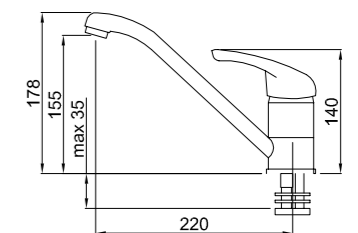





**focus** line

Unit No. 30-01-1857, Jewellery & Gemplex 3  
Plot No : DMCC-PH2-J&GPlexS Jewellery & Gemplex DUBAI – UAE  
contact@focusline.tn  
**www.focusline.tn**